

Collezione Grace

+

Collezione Beat

Collezione Grace

Grandi campiture di rose dai petali lucidi
coprono come in un fitto roseto
un morbido fondo satinato

Large expanses of bright petalled roses
cover a soft satin finish background,
like a luxuriant rose garden

Крупный узор из роз с блестящими
лепестками, подобно густым розовым
зарослям, покрывает мягкую матовую основу.

Carlo Dal Bianco





ED2060W
Grace Double White
20x60 cm - 45



ED2020W
Grace Double White
20x20 cm - 30

FONDI OPACHI

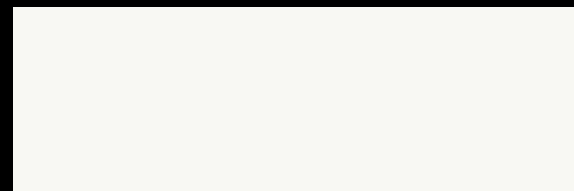

C2060W
White
20x60 cm - 30

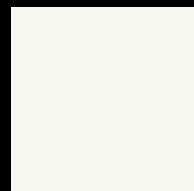

C2020W
White
20x20 cm - 2

W20W
Matita jolly White
1,2x20 cm - 0

FONDI LUCIDI

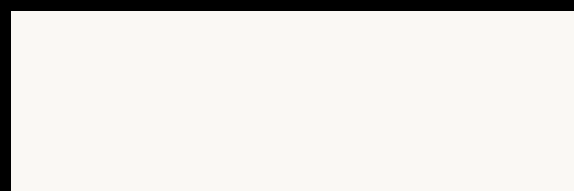

G2060NA
Narciso
20x60 cm - 35

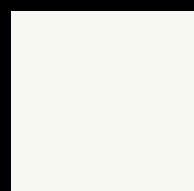

G2020NA
Narciso
20x20 cm - 0

G20NA
Matita jolly Narciso
1,2x20 cm - 0

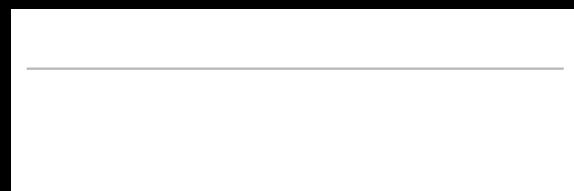

G80NA
Battiscopa
Narciso
20x60 cm - AQ

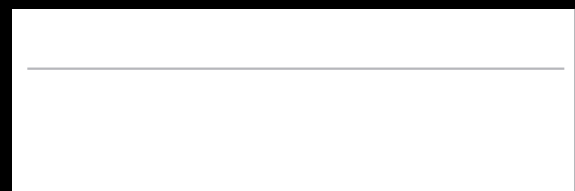

G80NAD
Battiscopa Narciso
smaltato lato destro
20x60 cm - AQ



G81NA
Angolo esterno
battiscopa
Narciso
2x20 cm - E

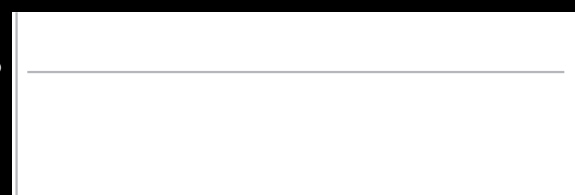

G80NAS
Battiscopa Narciso
smaltato lato sinistro
20x60 cm - AQ







ED2060BE
Grace Double Beige
20x60 cm - 45



ED2020BE
Grace Double Beige
20x20 cm - 30



E2060BE
Grace White Beige
20x60 cm - 45

FONDI OPACHI

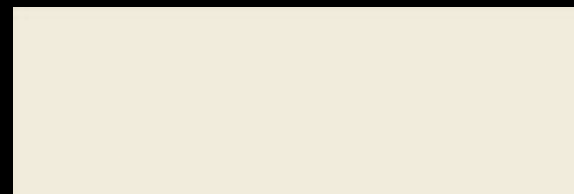

C2060BE
Beige
20x60 cm - 30

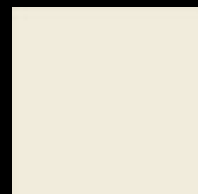

C2020BE
Beige
20x20 cm - 2



W20BE
Matita jolly Beige
1,2x20 cm - 0

FONDI LUCIDI



G2060GE
Gerbera
20x60 cm - 35

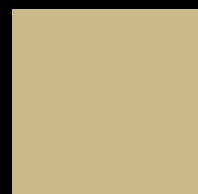

G2020GE
Gerbera
20x20 cm - 0

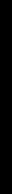

G20GE
Matita jolly Gerbera
1,2x20 cm - 0

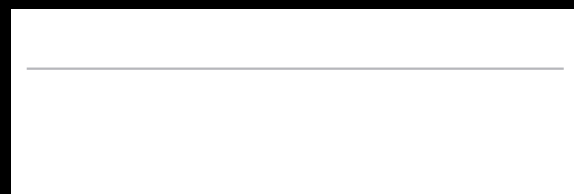

G80NA
Battiscopa
Narciso
20x60 cm - AO

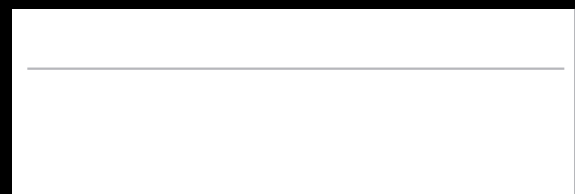

G80NAD
Battiscopa Narciso
smaltato lato destro
20x60 cm - AQ



G81NA
Angolo esterno
battiscopa
Narciso
2x20 cm - E

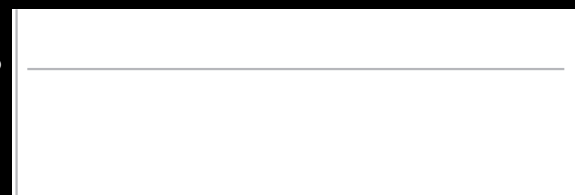

G80NAS
Battiscopa Narciso
smaltato lato sinistro
20x60 cm - AQ







ED2060BR
Grace Double Brown
20x60 cm - 45

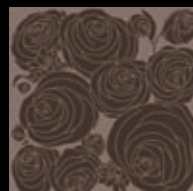

ED2020BR
Grace Double Brown
20x20 cm - 30



E2060BR
Grace White Brown
20x60 cm - 45

FONDI OPACHI



C2060BR
Brown
20x60 cm - 30

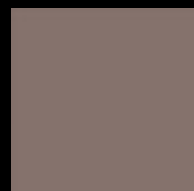

C2020BR
Brown
20x20 cm - 2



W20BR
Matita jolly Brown
1,2x20 cm - 0

FONDI LUCIDI



G2060CA
Calicanto
20x60 cm - 35



G2020CA
Calicanto
20x20 cm - 0



G20CA
Matita jolly Calicanto
1,2x20 cm - 0

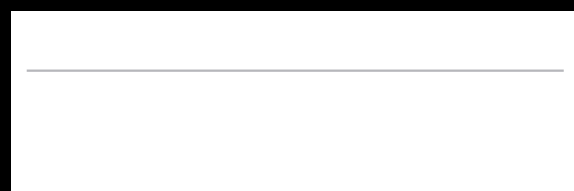

G80NA
Battiscopa
Narciso
20x60 cm - AO

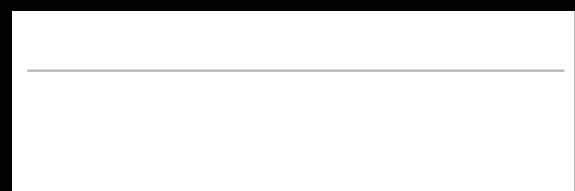

G80NAD
Battiscopa Narciso
smaltato lato destro
20x60 cm - AQ



G81NA
Angolo esterno
battiscopa
Narciso
2x20 cm - E

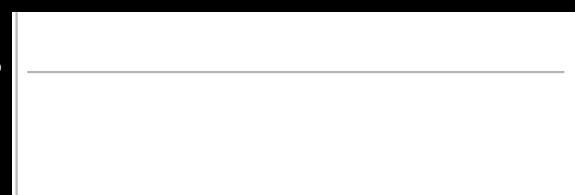

G80NAS
Battiscopa Narciso
smaltato lato sinistro
20x60 cm - AQ







ED2060BK
Grace Double Black
20x60 cm - 45

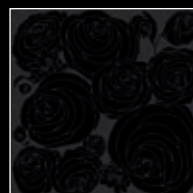

ED2020BK
Grace Double Black
20x20 cm - 30



E2060BK
Grace White Black
20x60 cm - 45

FONDI OPACHI

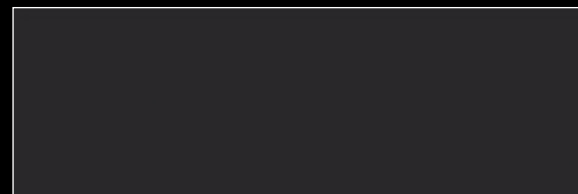

C2060BK
Black
20x60 cm - 30

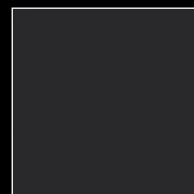

C2020BK
Black
20x20 cm - 2



W20BK
Matita jolly Black
1,2x20 cm - 0

FONDI LUCIDI

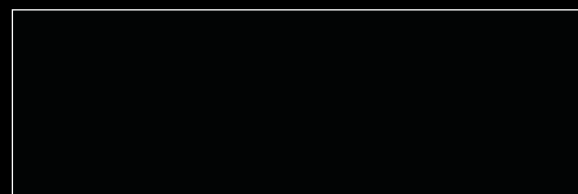

G2060EL
Eleboro
20x60 cm - 35



G2020EL
Eleboro
20x20 cm - 0



G20EL
Matita jolly Eleboro
1,2x20 cm - 0

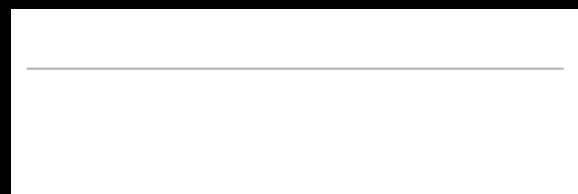

G80NA
Battiscopa
Narciso
20x60 cm - AO

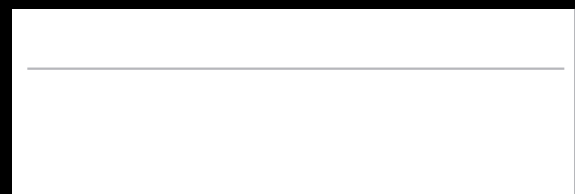

G80NAD
Battiscopa Narciso
smaltato lato destro
20x60 cm - AQ



G81NA
Angolo esterno
battiscopa
Narciso
2x20 cm - E

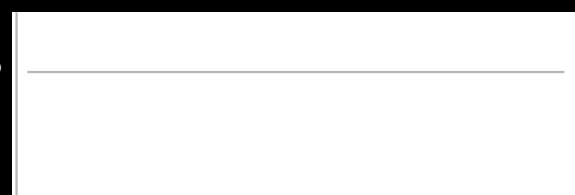

G80NAS
Battiscopa Narciso
smaltato lato sinistro
20x60 cm - AQ







ED2060P
Grace Double Pink
20x60 cm - 45



ED2020P
Grace Double Pink
20x20 cm - 30



E2060P
Grace White Pink
20x60 cm - 45

FONDI OPACHI

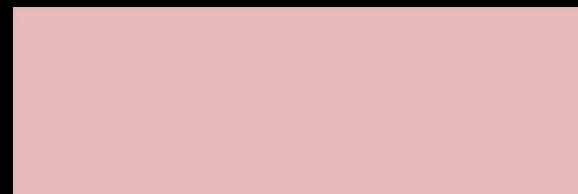

C2060P
Pink
20x60 cm - 30

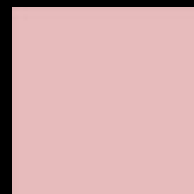

C2020P
Pink
20x20 cm - 2



W20P
Matita jolly Pink
1,2x20 cm - 0

FONDI LUCIDI



G2060CI
Ciclamino
20x60 cm - 35



G2020CI
Ciclamino
20x20 cm - 0



G20CI
Matita jolly Ciclamino
1,2x20 cm - 0

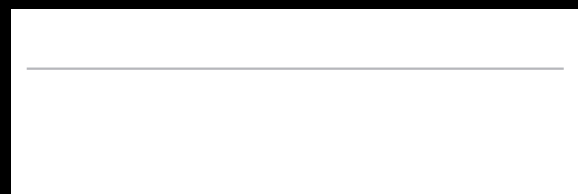

G80NA
Battiscopa
Narciso
20x60 cm - AO

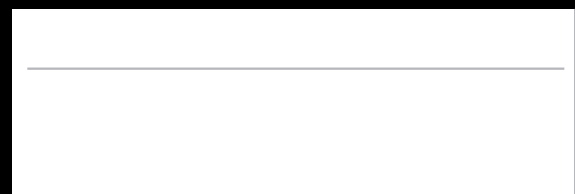

G80NAD
Battiscopa Narciso
smaltato lato destro
20x60 cm - AQ



G81NA
Angolo esterno
battiscopa
Narciso
2x20 cm - E

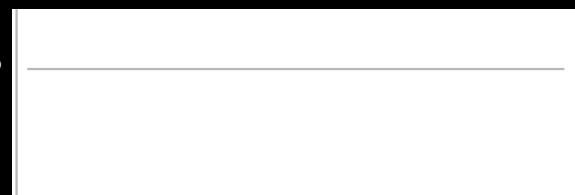

G80NAS
Battiscopa Narciso
smaltato lato sinistro
20x60 cm - AQ







ED2060BL
Grace Double Blue
20x60 cm - 45



ED202BL
Grace Double Blue
20x20 cm - 30



E2060BL
Grace White Blue
20x60 cm - 45

FONDI OPACHI



C2060BL
Blue
20x60 cm - 30



C2020BL
Blue
20x20 cm - 2



W20BL
Matita jolly Blue
1,2x20 cm - 0

FONDI LUCIDI



G2060DA
Dalia
20x60 cm - 35



G2020DA
Dalia
20x20 cm - 0

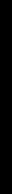

G20DA
Matita jolly Dalia
1,2x20 cm - 0

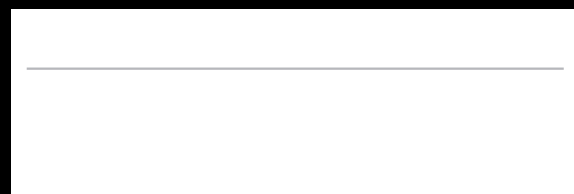

G80NA
Battiscopa
Narciso
20x60 cm - AO

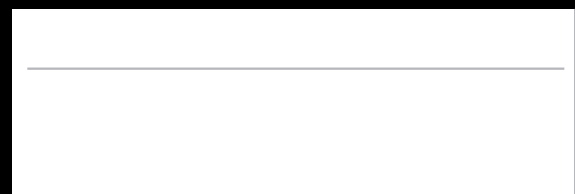

G80NAD
Battiscopa Narciso
smaltato lato destro
20x60 cm - AQ



G81NA
Angolo esterno
battiscopa
Narciso
2x20 cm - E

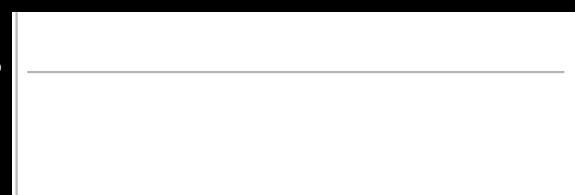

G80NAS
Battiscopa Narciso
smaltato lato sinistro
20x60 cm - AQ







ED2060G
Grace Double Green
20x60 cm - 45



ED2020G
Grace Double Green
20x20 cm - 30



E2060G
Grace White Green
20x60 cm - 45

FONDI OPACHI



C2060G
Green
20x60 cm - 30



C2020G
Green
20x20 cm - 2



W20G
Matita jolly Green
1,2x20 cm - 0

FONDI LUCIDI



G2060ED
Edera
20x60 cm - 35



G2020ED
Edera
20x20 cm - 0



G20ED
Matita jolly Edera
1,2x20 cm - 0

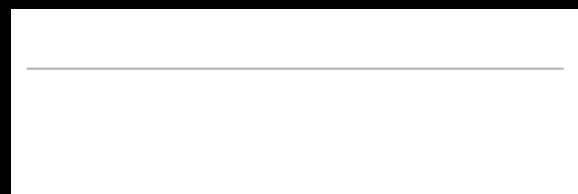

G80NA
Battiscopa
Narciso
20x60 cm - AQ

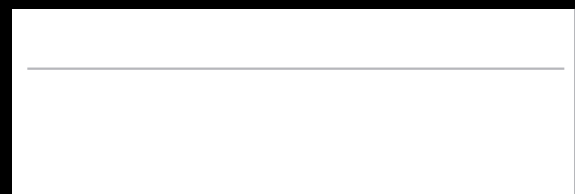

G80NAD
Battiscopa Narciso
smaltato lato destro
20x60 cm - AQ



G81NA
Angolo esterno
battiscopa
Narciso
2x20 cm - E

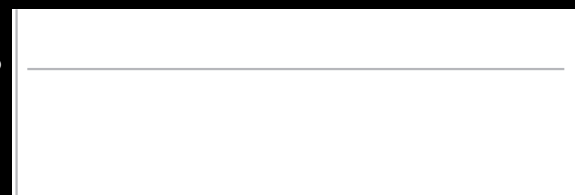

G80NAS
Battiscopa Narciso
smaltato lato sinistro
20x60 cm - AQ



Grace

Area Tecnica
Technical section
ТЕХНИЧЕСКИЙ РАЗДЕЛ



ED2060W
Grace Double White
20x60 cm - 45



ED2020W
Grace Double White
20x20 cm - 30



E2060W
Grace Double White
20x60 cm - 45



ED2060BE
Grace Double Beige
20x60 cm - 45



ED2020BE
Grace Double Beige
20x20 cm - 30



E2060BE
Grace White Beige
20x60 cm - 45



ED2060BR
Grace Double Brown
20x60 cm - 45



ED2020BR
Grace Double Brown
20x20 cm - 30



E2060BR
Grace White Brown
20x60 cm - 45



ED2060BK
Grace Double Black
20x60 cm - 45

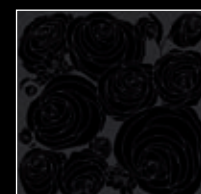

ED2020BK
Grace Double Black
20x20 cm - 30



E2060BK
Grace White Black
20x60 cm - 45



ED2060P
Grace Double Pink
20x60 cm - 45



ED2020P
Grace Double Pink
20x20 cm - 30



E2060P
Grace White Pink
20x60 cm - 45



ED2060BL
Grace Double Blue
20x60 cm - 45



ED2020BL
Grace Double Blue
20x20 cm - 30



E2060BL
Grace White Blue
20x60 cm - 45



ED2060G
Grace Double Green
20x60 cm - 45



ED2020G
Grace Double Green
20x20 cm - 30



E2060G
Grace White Green
20x60 cm - 45

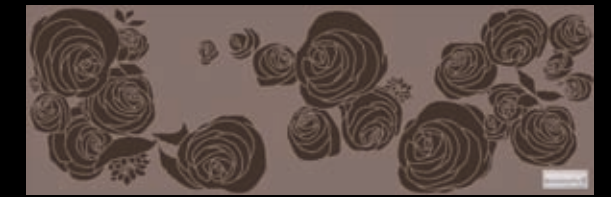

MARCHION26
Marchio 20x60 cm - F



MARCHION22
Marchio 20x20 cm - H



MARCHIO26
Marchio 20x60 cm - L



MARCHIO22
Marchio 20x20 cm - N



MARCHIO26
Marchio 20x60 cm - L













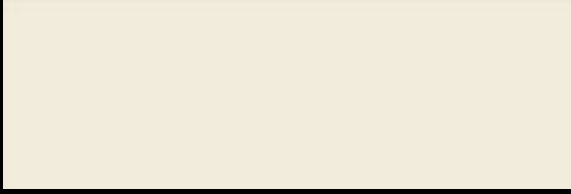
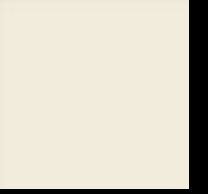

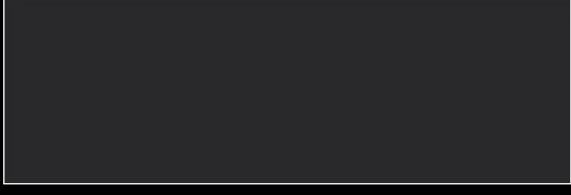
MARCHIO22
Marchio 20x20 cm - N

MARCHIO DECORATORISTYLE. Il marchio è disponibile in tutte le varianti colore.

MARCHIO DECORATORISTYLE. The logo tile is available in all colour variations.

MARCHIO DECORATORISTYLE. Плитка с маркой выпускается всех цветов

	C2060W White 20x60 cm - 30		C2020W White 20x20 cm - 2	W20W Matita jolly White 1,2x20 cm - 0
	C2060BE Beige 20x60 cm - 30		C2020BE Beige 20x20 cm - 2	W20BE Matita jolly Beige 1,2x20 cm - 0
	C2060BR Brown 20x60 cm - 30		C2020BR Brown 20x20 cm - 2	W20BR Matita jolly Brown 1,2x20 cm - 0
	C2060BK Black 20x60 cm - 30		C2020BK Black 20x20 cm - 2	W20BK Matita jolly Black 1,2x20 cm - 0
	C2060P Pink 20x60 cm - 30		C2020P Pink 20x20 cm - 2	W20P Matita jolly Pink 1,2x20 cm - 0
	C2060BL Blue 20x60 cm - 30		C2020BL Blue 20x20 cm - 2	W20BL Matita jolly Blue 1,2x20 cm - 0
	C2060G Green 20x60 cm - 30		C2020G Green 20x20 cm - 2	W20G Matita jolly Green 1,2x20 cm - 0

	G2060NA Narciso 20x60 cm - 35		G2020NA Narciso 20x20 cm - 0	G20NA Matita jolly Narciso 1,2x20 cm - 0
	G2060GE Gerbera 20x60 cm - 35		G2020GE Gerbera 20x20 cm - 0	G20GE Matita jolly Gerbera 1,2x20 cm - 0
	G2060CA Calicanto 20x60 cm - 35		G2020CA Calicanto 20x20 cm - 0	G20CA Matita jolly Calicanto 1,2x20 cm - 0
	G2060EL Elleboro 20x60 cm - 35		G2020EL Elleboro 20x20 cm - 0	G20EL Matita jolly Elleboro 1,2x20 cm - 0
	G2060CI Ciclamino 20x60 cm - 35		G2020CI Ciclamino 20x20 cm - 0	G20CI Matita jolly Ciclamino 1,2x20 cm - 0
	G2060DA Dalia 20x60 cm - 35		G2020DA Dalia 20x20 cm - 0	G20DA Matita jolly Dalia 1,2x20 cm - 0
	G2060ED Edera 20x60 cm - 35		G2020ED Edera 20x20 cm - 0	G20ED Matita jolly Edera 1,2x20 cm - 0

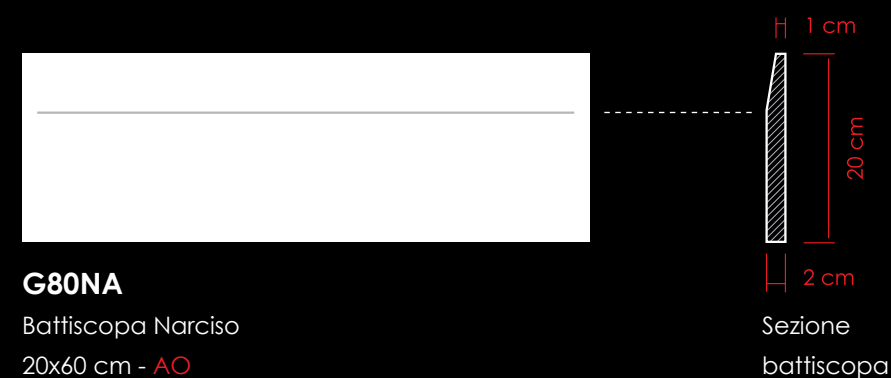

Lavabo da appoggio
Above top washbasin
НАСТОЛЬНЫЙ УМЫВАЛЬНИК



T50
 Lavabo
 50,5x50,5x14,5 cm

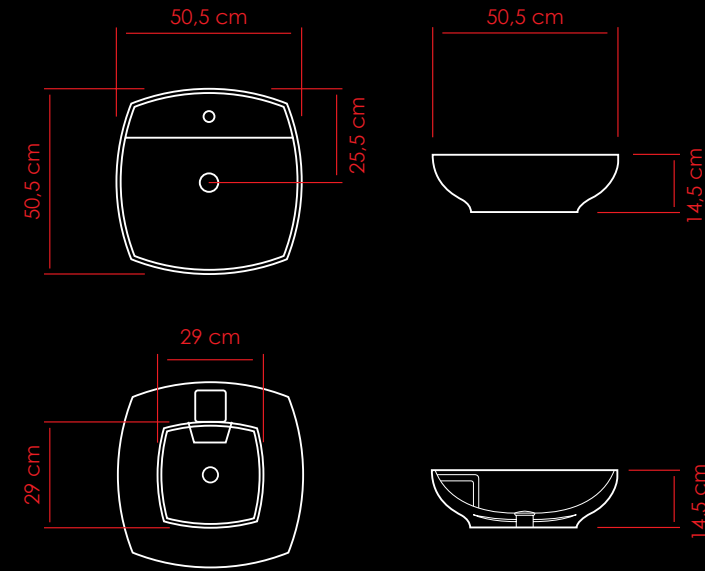

Lavabo sospeso con staffa di sostegno
Wall-mounted washbasin with bracket
Подвесной умывальник с опорным кронштейном



T50
 Lavabo
 50,5x50,5x14,5 cm

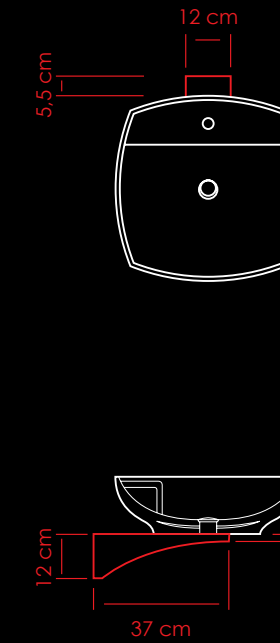

ST50
 Staffa di sostegno
 37x12 cm

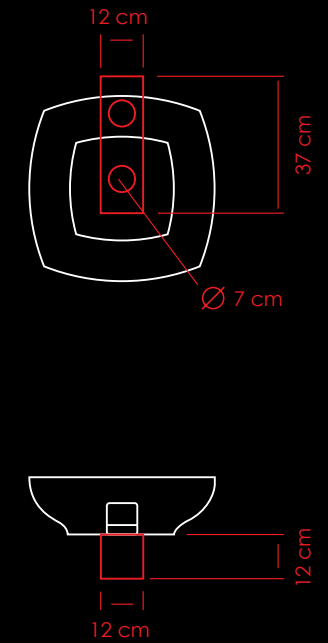

T80
 Lavabo
 52x81x14,5 cm

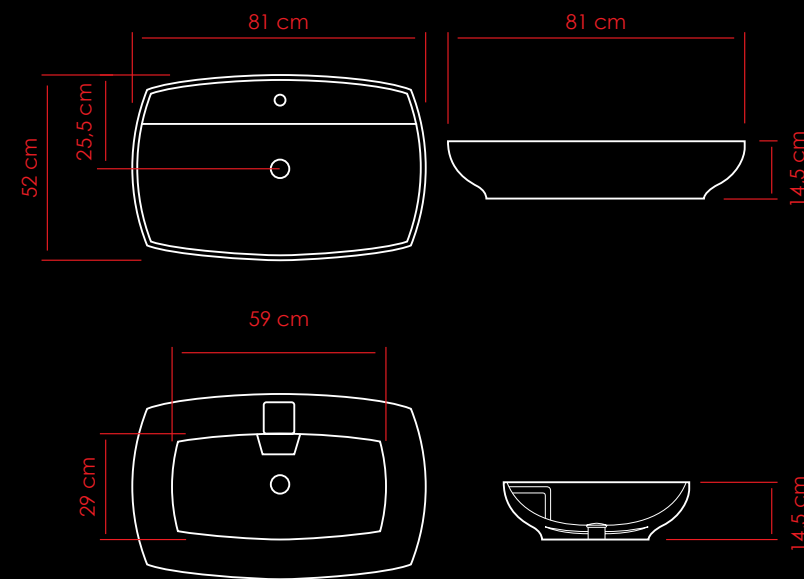

T80
 Lavabo
 52x81x14,5 cm

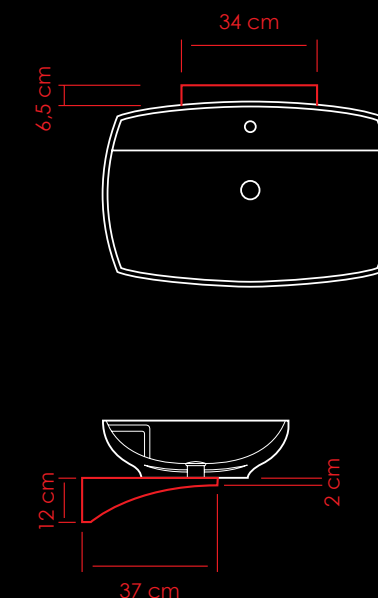

ST80
 Staffa di sostegno
 37x34 cm

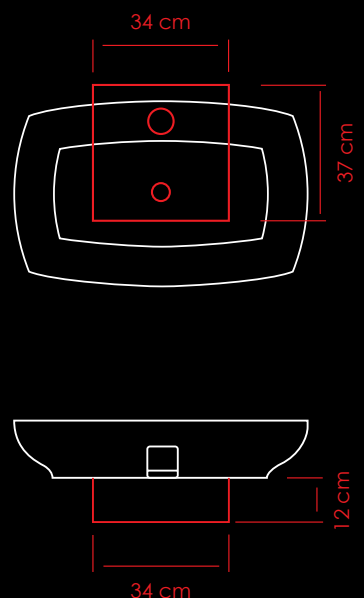



Vaso - WC - УНИТАЗ

TV
Vaso
38x54 cm

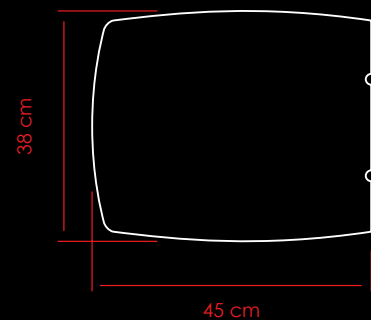
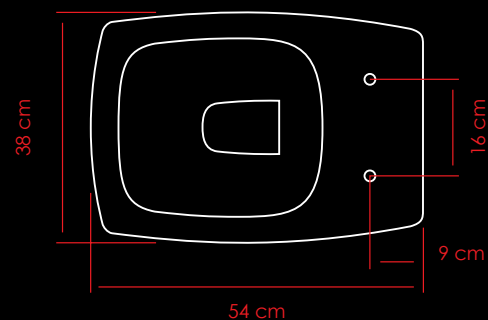

TC
Copri Vaso
con chiusura soft

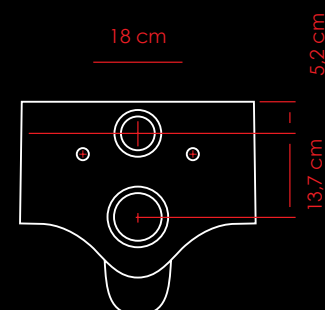
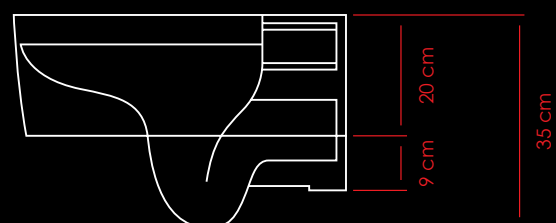

Bidet - Bidet - БИДЕ

TB
Bidet
38x54 cm

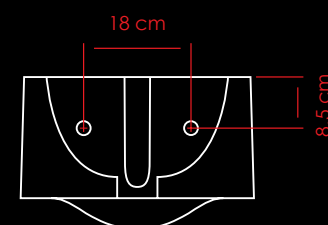
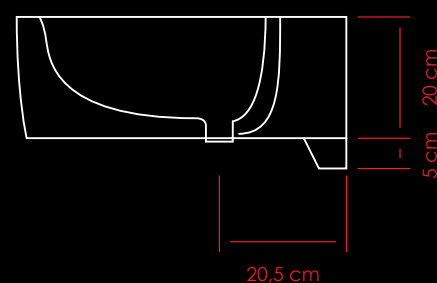
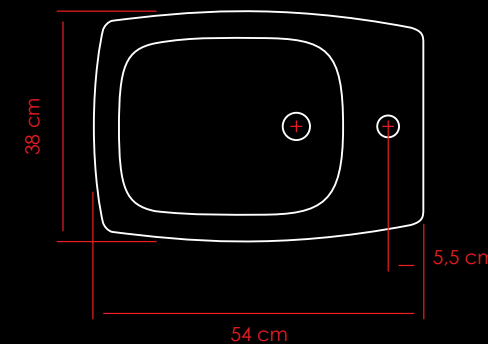

SCHEDA TECNICA

FONDI (Bicottura)

La lavorazione di questi fondi è articolata in più passaggi al fine di creare un prodotto ricercato e curato nel dettaglio. Alla cottura del cottoforte seguono varie lavorazioni: molteplici stratificazioni di smalti e cristalline che rendono il prodotto profondo ed estremamente morbido nella superficie. I fondi subiscono una lavorazione a doppio velo, un doppio passaggio di cristalline e smalti che permette di ottenere una profondità di prodotto unica.

FONDI OPACHI

In un metro quadrato sono presenti circa 3,0 kg di smalto e cristalline.

Successivamente a queste lavorazioni il prodotto subisce una ulteriore cottura a 1.050 gradi, nel quale lo smalto si fissa al supporto.

Piccole variazioni di lucentezza e di colore sulla superficie sono il risultato di lavorazioni artigianali che conferiscono pregio ed unicità ad ogni singola lavorazione

FONDI LUCIDI

In un metro quadrato sono presenti circa 3,2 kg di smalto e cristalline.

Successivamente a queste lavorazioni il prodotto subisce una ulteriore cottura a 1.050 gradi, nel quale lo smalto si fissa al supporto.

Piccoli fori e leggere imperfezioni in superficie sono il risultato della stesura consistente di smalto e delle successive lavorazioni ricercate.

Possibili effetti craquelè (cavillo) si possono presentare occasionalmente soprattutto dopo la posa, derivanti da sollecitazioni meccaniche di trazione sulla strato consistente di smalto. L'effetto non si presenta se non in rare condizioni.

I fondi lucidi ed opachi sono disponibili nei formati 20x20 e 20x60, entrambi in spessore 1 cm.

Si consiglia un uso del prodotto da interno, pavimento per ambienti bagno, rivestimento per qualsiasi ambiente.

ISTRUZIONI PER LA POSA E LA STUCCATURA DEL PRODOTTO

Inizialmente si deve procedere ad una corretta preparazione del sottofondo in modo che sia pulito, asciutto ed esente da umidità, senza crepe e non deve presentare dislivelli di planarità.

Si consiglia di utilizzare un adesivo monocomponente per piastrelle in ceramica a base cementizia ad alta adesione, buona deformabilità e scivolamento verticale nullo.

MAPEI KERAFLEX MAXI S1 - MAPEI ELASTORAPID
KERAKOLL SPECIAL - KERAKOLL H40 FLEX

Per fughe utilizzare stucco a grana fine, a ridotto assorbimento d'acqua, a presa ed asciugamento rapido.

MAPEI ULTRACOLOR PLUS (malta ad alte prestazioni, antiflorescenze, idrorepellente, a presa ed asciugamento rapido per la stuccatura di fughe da 2 a 20 mm)

KERAKOLL FUGABELLA PORCELANA 0-5 (stucco porcellanato fine professionale monocomponente a tecnologia microgranulare, elevata durezza, ridotto assorbimento d'acqua)

KERAKOLL FUGABELLA 2-12 (per le fughe da 2 a 12 mm stucco professionale monocomponente a finitura liscia calibrata, elevata durezza e ridotto assorbimento d'acqua)

Per le caratteristiche e le modalità d'impiego dei materiali indicati si rimanda alle relative schede tecniche.

La Decoratori Bassanesi S.r.l per nessun motivo accoglierà contestazioni sul materiale posato.

I colori di prodotti riportati nel presente catalogo sono puramente indicativi dei colori reali.

PRODUCT DATA SHEET

PLAIN TILES (double fired)

These tiles are manufactured by a process involving several stages, designed to produce a stylish and expertly crafted product. After firing, cottoforte undergoes a number of processing steps: several layers of glaze giving the product depth, and making it extremely soft to the touch.

Plain tiles undergo a dual layer process — two applications of glaze slips combining to produce a finish of unique depth and colour.

PLAIN TILES, MATTE:

One square metre of tiling contains around 3.0 kg of glaze and microcrystal.

Following the sequence of glazing steps, the tiles are fired for a second time at 1,050 degrees to anchor the glaze to the ceramic body.

Slight variations in surface brightness and colour are the result of traditional craft techniques by which every step of the process is rendered special and unique.

PLAIN TILES, GLOSS

One square metre of tiling contains around 3.2 kg of glaze and microcrystal.

Following the sequence of glazing steps, the tiles are fired for a second time at 1,050 degrees to anchor the glaze to the ceramic body.

Any pinholes and minor imperfections in the surface are quite normal, given the thickness of the glaze and the special process adopted.

Crazing may appear in the glaze, especially after the tiles have been bonded to the substrate, due likewise to the depth of the glaze and the mechanical stresses induced during installation. In practice however, this will rarely occur.

Plain tiles, gloss and matte are made in 20x20 and 20x60 sizes, both 1 cm thick.

Because the particular texture of the glaze are easily defaced, great care should be taken when handling and during installation.

The product is intended for internal use, typically on bathroom floors, and as a wall covering for any interior.

INSTRUCTIONS FOR INSTALLATION AND GROUTING

The first step is to ensure correct preparation of the substrate, which must be clean, dry, devoid of residual moisture and with no cracks. The surface must be perfectly flat.

For best results, select a ready-to-use cement-based tile adhesive with strong bonding properties, good flexibility and zero vertical slippage.

MAPEI KERAFLEX MAXI S1 - MAPEI ELASTORAPID
KERAKOLL SPECIAL - KERAKOLL H40 FLEX

Use a fine grade grouting cement with low water absorption, preferably fast-setting and fast-drying.

MAPEI ULTRACOLOR PLUS (high performance grouting mortar with efflorescence-inhibiting, water-repellent, fast-setting and fast-drying properties, for gaps of 2 to 20 mm)

KERAKOLL FUGABELLA PORCELANA 0-5 (ready-to-use professional vitreous grouting cement featuring microgranule technology; offers superior hardness and low water absorption)

KERAKOLL FUGABELLA 2-12 (ready-to-use professional grouting cement featuring smooth finish, superior hardness and low water absorption, for gaps of 2 to 12 mm)

For specifications and recommended use of the materials indicated, refer to the relative technical data sheets.

Decoratori Bassanesi S.r.l will under no circumstances accept complaints regarding material post-installation.

Actual product colours may differ from the colours shown in this catalogue, which are purely indicative.

ОДНОТОННАЯ ПЛИТКА (двукратного обжига)

Обработка однотонной плитки выполняется в несколько приемов с целью создания изысканной продукции с тщательно разработанными деталями.

За обжигом бисквита (коттофорте) следуют различные этапы обработки: наносятся многочисленные слои глазури, которые придают изделию глубину и чрезвычайную мягкость поверхности на ощупь.

Однотонная плитка подвергается обработке с т.н. двойным слоем, то есть двойной этап нанесения цветной глазури, благодаря которому достигается уникальная глубина изделия.

матовая фоновая плитка

На одном квадратном метре материала имеются прибл. 3,0 кг цветной глазури.

После данной обработки изделия еще раз обжигаются при температуре 1050 градусов, и на этом этапе глазурь закрепляется на основе.

Небольшие изменения блеска и цвета на поверхности являются результатом ручной обработки, придающей ценный и уникальный характер каждому отдельному этапу.

глянцевая фоновая плитка

На одном квадратном метре материала имеются прибл. 3,2 кг цветной и прозрачной глазури.

После данной обработки изделия еще раз обжигаются при температуре 1050 градусов, и на этом этапе глазурь закрепляется на основе.

Небольшие отверстия и легкие поверхностные дефекты являются результатом нанесения большого количества глазури и последующей сложной обработки.

Возможный эффект кракелюры (трещинок) может возникнуть в любое время, особенно после укладки, в связи с механической тягой на толстый слой глазури. Этот эффект появляется очень редко.

глянцевая и матовая фоновая плитка Форматы однотонной плитки – 20x20 и 20x60 см, толщина обоих форматов составляет 1 см. Данную продукцию рекомендуется использовать в помещениях, для

настила полов в ванных комнатах, или же для облицовки стен в любых других помещениях.

ИНСТРУКЦИЯ ПО УКЛАДКЕ ИЗДЕЛИЙ И ЗАДЕЛЫВАНИЮ ШВОВ

Сначала необходимо правильно подготовить подстилающий слой, который должен быть чистым, сухим и без следов влаги, без трещин и перепадов уровня.

Рекомендуем использовать однокомпонентный клей для керамической плитки на цементной основе с высокой склеивающей способностью, хорошей деформируемостью и нулевым вертикальным скольжением.

**MAPEI KERAFLEX MAXI S1 - MAPEI ELASTORAPID
KERAKOLL SPECIAL – KERAKOLL H40 FLEX**

Для швов использовать затирку с мелкой зернистостью, с пониженным поглощением воды, быстросхватывающуюся и быстро сохнущую.

MAPEI ULTRACOLOR PLUS (затирка с высокими характеристиками, не образующая налеты, водоотталкивающая, быстросхватывающаяся и быстро сохнущая для заделки швов толщиной от 2 до 20 мм).

KERAKOLL FUGABELLA PORCELANA 0-5 (однокомпонентная тонкая фарфоровая затирка для профессионального применения, с микрогранулами, повышенной твердостью и умеренным поглощением воды).

KERAKOLL FUGABELLA 2-12 (для швов толщиной от 2 до 12 мм. Это однокомпонентная затирка для профессионального применения с гладкой калиброванной отделкой, повышенной твердостью и умеренным поглощением воды).

Характеристики и способ применения указанных материалов смотри в соответствующих технических характеристиках.

Компания Decoratori Bassanesi S.r.l. ни в коем случае не принимает претензии по уложенному материалу.

Указанные в настоящем каталоге цвета продукции являются лишь только ориентировочными по сравнению с фактическими.

Cartella colori stucchi

Si suggerisce di utilizzare per ogni colore di fondo lo stucco in coordinato riportato nella cartella

Grout colour chart

It is advisable to use the matching grout for each colour of plain tile, as indicated in the chart

цветовая гамма затирки

для каждого цвета однотонной плитки рекомендуем использовать сочетающуюся затирку, указанную в цветовой гамме

white	Mapei Ultracolor Plus n° 100	Kerakoll Fugabella Porcelana n° 01
beige	Mapei Ultracolor Plus n° 100	Kerakoll Fugabella Porcelana n° 01
brown	Mapei Ultracolor Plus n° 144	Kerakoll Fugabella Porcelana n° 12
black	Mapei Ultracolor Plus n° 120	Kerakoll Fugabella Porcelana n° 05
pink	Mapei Ultracolor Plus n° 140	Kerakoll Fugabella Porcelana n° 25
blue	Mapei Ultracolor Plus n° 110	Kerakoll Fugabella Porcelana n° 02
green	Mapei Ultracolor Plus n° 112	Kerakoll Fugabella Porcelana n° 03

Collezione Beat

Il gioco dei colori e delle superfici lucide ed opache interpreta gli entusiasmi e la vitalità anticonformista degli anni sessanta

The interplay of colours and of glossy and matte surfaces evokes the high optimism and rebellious vitality of the nineteen-sixties

Игра, созданная при помощи цвета, глянцевых и матовых поверхностей, выражает характерные для шестидесятых годов энтузиазм и наполненную антиконформизмом жизненную силу.

Carlo Dal Bianco



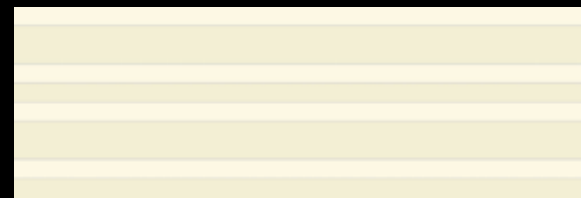

BE26BG
Beat Colore Beige-Gardenia
20x60 cm - B

FONDI OPACHI

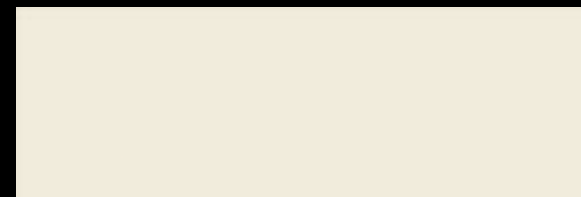

C2060BE
Beige
20x60 cm - 30

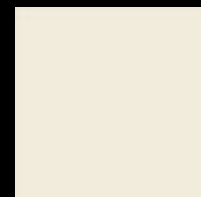

C2020BE
Beige
20x20 cm - 2

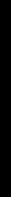

W20BE
Matita jolly Beige
1,2x20 cm - O

FONDI LUCIDI

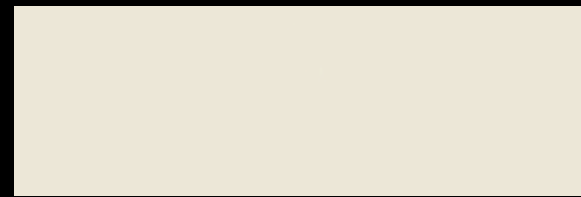

G2060GA
Gardenia
20x60 cm - 35

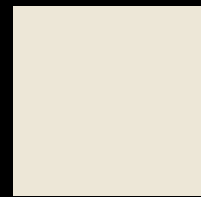

G2020GA
Gardenia
20x20 cm - 0

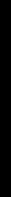

G20GA
Matita jolly Gardenia
1,2x20 cm - O

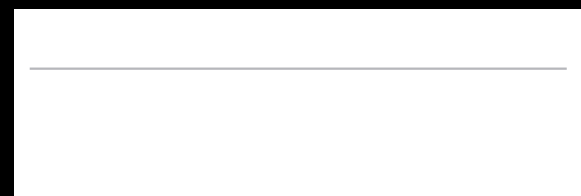

G80NA
Battiscopa
Narciso
20x60 cm - AO

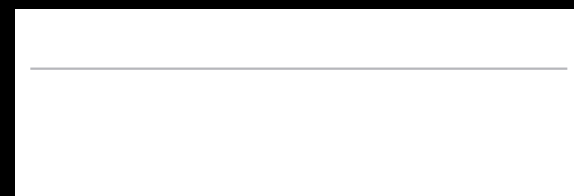

G80NAD
Battiscopa Narciso
smaltato lato destro
20x60 cm - AQ



G81NA
Angolo esterno
battiscopa
Narciso
2x20 cm - E

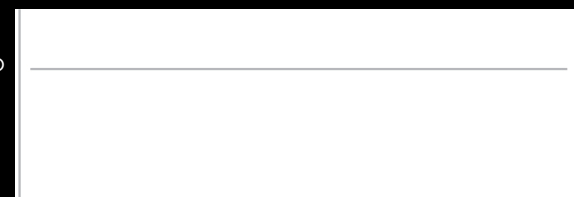

G80NAS
Battiscopa Narciso
smaltato lato sinistro
20x60 cm - AQ







BE26EN
Beat Bicolore Elleboro-Narciso
20x60 cm - E

FONDI LUCIDI



G2060EL
Elleboro
20x60 cm - 35

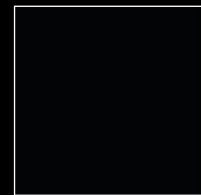

G2020EL
Elleboro
20x20 cm - 0



G20EL
Matita jolly Elleboro
1,2x20 cm - 0

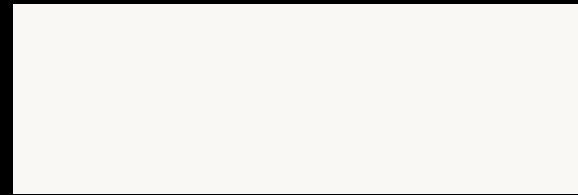

G2060NA
Narciso
20x60 cm - 35

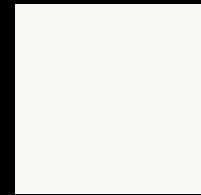

G2020NA
Narciso
20x20 cm - 0



G20NA
Matita jolly Narciso
1,2x20 cm - 0

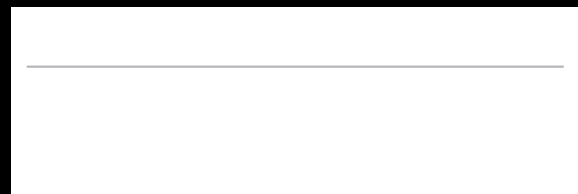

G80NA
Battiscopa
Narciso
20x60 cm - AO

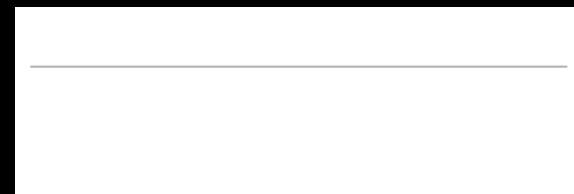

G80NAD
Battiscopa Narciso
smaltato lato destro
20x60 cm - AQ



G81NA
Angolo esterno
battiscopa
Narciso
2x20 cm - E

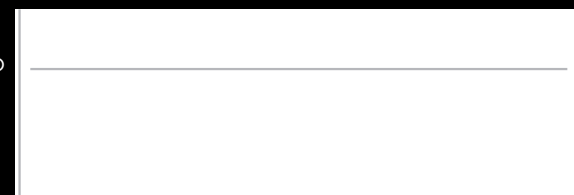

G80NAS
Battiscopa Narciso
smaltato lato sinistro
20x60 cm - AQ







BE26CB
Beat Colore Calicanto-Brown
20x60 cm - B

FONDI OPACHI



C2060BR
Brown
20x60 cm - 30

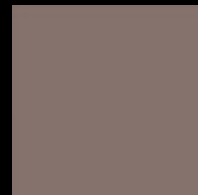

C2020BR
Brown
20x20 cm - 2



W20BR
Matita jolly Brown
1,2x20 cm - O

FONDI LUCIDI



G2060CA
Calicanto
20x60 cm - 35



G2020CA
Calicanto
20x20 cm - 0



G20CA
Matita jolly Calicanto
1,2x20 cm - O

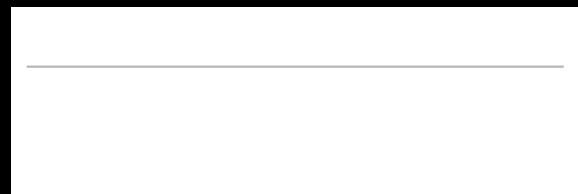

G80NA
Battiscopa
Narciso
20x60 cm - AO

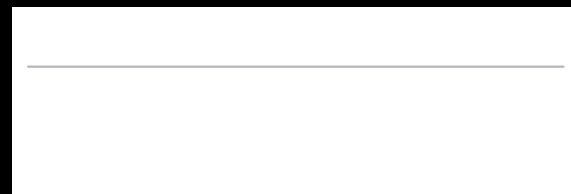

G80NAD
Battiscopa Narciso
smaltato lato destro
20x60 cm - AQ



G81NA
Angolo esterno
battiscopa
Narciso
2x20 cm - E

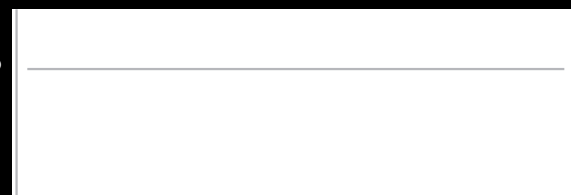

G80NAS
Battiscopa Narciso
smaltato lato sinistro
20x60 cm - AQ





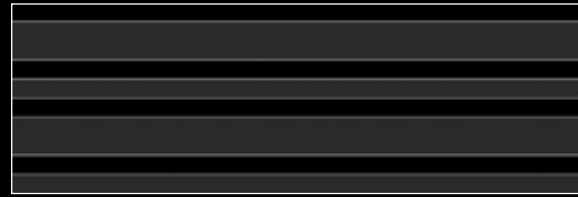

BE26EB
Beat Colore Elleboro-Black
20x60 cm - B

FONDI OPACHI



C2060BK
Black
20x60 cm - 30

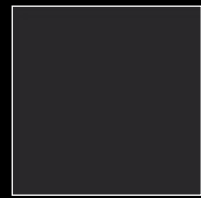

C2020BK
Black
20x20 cm - 2



W20BK
Matita jolly Black
1,2x20 cm - O

FONDI LUCIDI



G2060EL
Elleboro
20x60 cm - 35

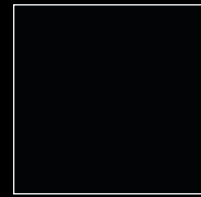

G2020EL
Elleboro
20x20 cm - 0



G20EL
Matita jolly Elleboro
1,2x20 cm - O

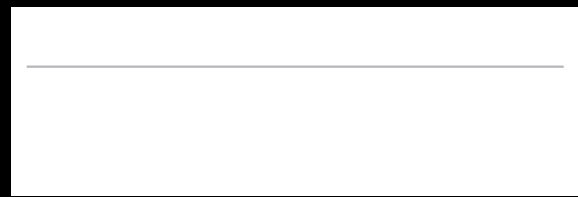

G80NA
Battiscopa
Narciso
20x60 cm - AO

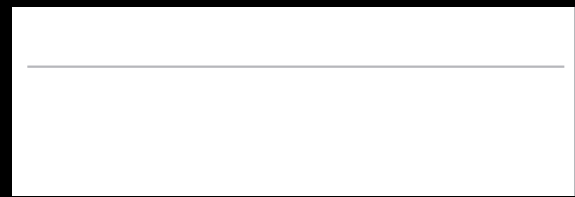

G80NAD
Battiscopa Narciso
smaltato lato destro
20x60 cm - AQ



G81NA
Angolo esterno
battiscopa
Narciso
2x20 cm - E

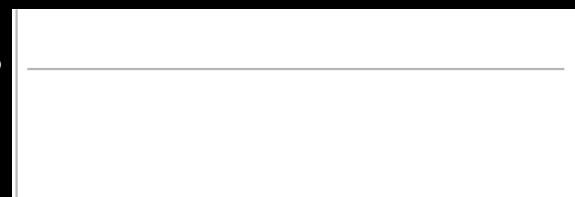

G80NAS
Battiscopa Narciso
smaltato lato sinistro
20x60 cm - AQ







BE26CPN
Beat Multicolore Ciclamino-Pink-Ninfea
20x60 cm - B

FONDI OPACHI

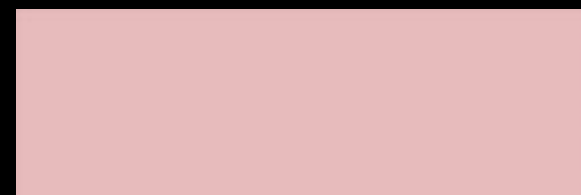

C2060P
Pink
20x60 cm - 30

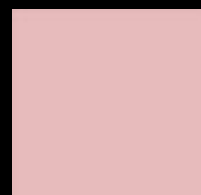

C2020P
Pink
20x20 cm - 2



W20P
Matita jolly Pink
1,2x20 cm - O

FONDI LUCIDI



G2060NI
Ninfea
20x60 cm - 35



G2020NI
Ninfea
20x20 cm - 0



G20NI
Matita jolly Ninfea
1,2x20 cm - O

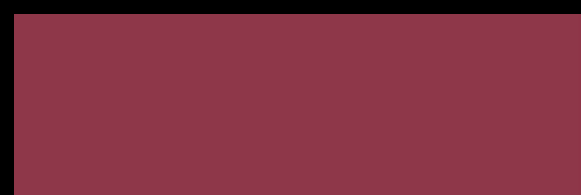

G2060CI
Ciclamino
20x60 cm - 35



G2020CI
Ciclamino
20x20 cm - 0



G20CI
Matita jolly Ciclamino
1,2x20 cm - O

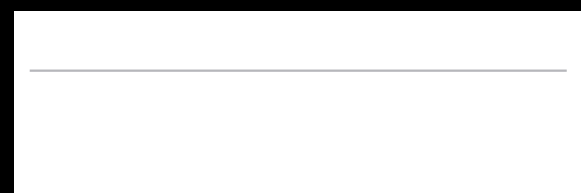

G80NA
Battiscopa
Narciso
20x60 cm - AO

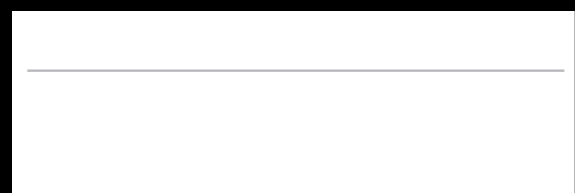

G80NAD
Battiscopa Narciso
smaltato lato destro
20x60 cm - AQ



G81NA
Angolo esterno
battiscopa
Narciso
2x20 cm - E

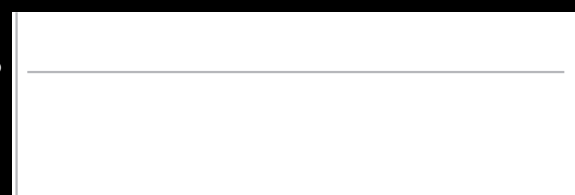

G80NAS
Battiscopa Narciso
smaltato lato sinistro
20x60 cm - AQ





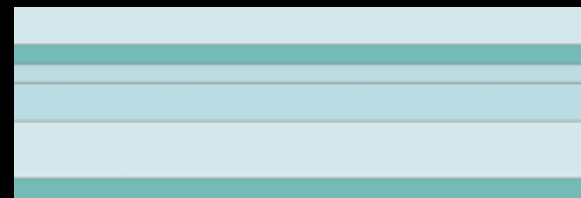

BE26DBO
Beat Multicolore Dalia-Blue-Ortensia
20x60 cm - B

FONDI OPACHI

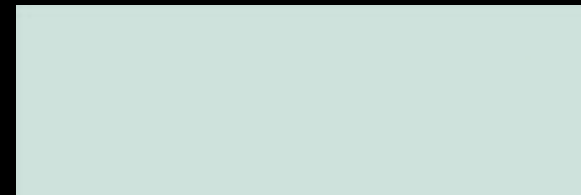

C2060BL
Blue
20x60 cm - 30

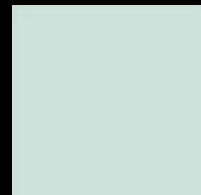

C2020BL
Blue
20x20 cm - 2



W20BL
Matita jolly Blue
1,2x20 cm - O

FONDI LUCIDI



G2060OR
Ortensia
20x60 cm - 35

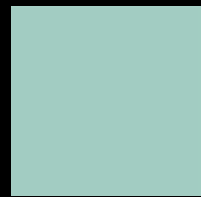

G2020OR
Ortensia
20x20 cm - 0



G20OR
Matita jolly Ortensia
1,2x20 cm - O



G2060DA
Dalia
20x60 cm - 35



G2020DA
Dalia
20x20 cm - 0



G20DA
Matita jolly Dalia
1,2x20 cm - O

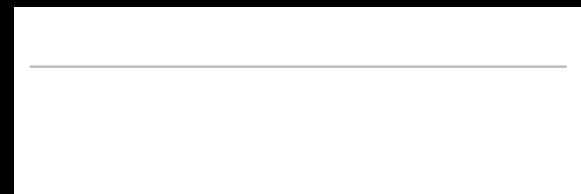

G80NA
Battiscopa
Narciso
20x60 cm - AO

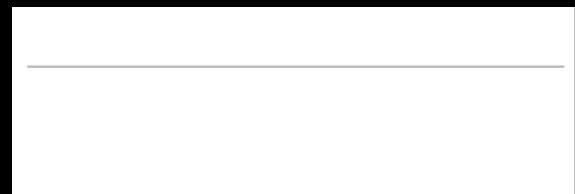

G80NAD
Battiscopa Narciso
smaltato lato destro
20x60 cm - AQ



G81NA
Angolo esterno
battiscopa
Narciso
2x20 cm - E

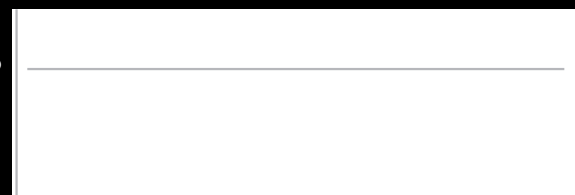

G80NAS
Battiscopa Narciso
smaltato lato sinistro
20x60 cm - AQ



Beat

Area Tecnica
Technical section
ТЕХНИЧЕСКИЙ РАЗДЕЛ



BE26BG
Beat Colore Beige-Gardenia
20x60 cm - B

FONDI OPACHI - PLAIN TILES, MATTE - МАТОВАЯ ФОНОВАЯ ПЛИТКА

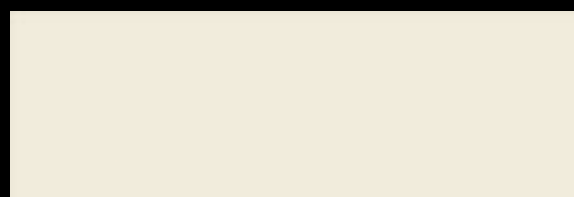

C2060BE
Beige
20x60 cm - 30

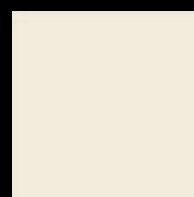

C2020BE
Beige
20x20 cm - 2



W20BE
Matita jolly Beige
1,2x20 cm - O

FONDI LUCIDI - PLAIN TILES, GLOSS - ГЛЯНЦЕВАЯ ФОНОВАЯ ПЛИТКА

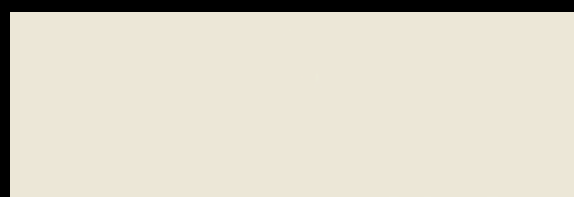

G2060GA
Gardenia
20x60 cm - 35



G2020GA
Gardenia
20x20 cm - 0



G20GA
Matita jolly Gardenia
1,2x20 cm - O

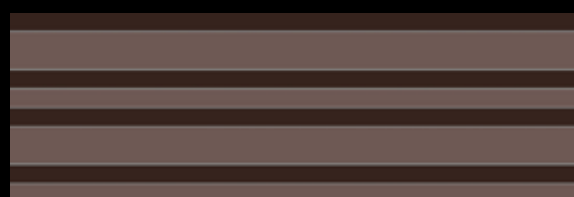

BE26CB
Beat Colore Calicanto-Brown
20x60 cm - B

FONDI OPACHI - PLAIN TILES, MATTE - МАТОВАЯ ФОНОВАЯ ПЛИТКА



C2060BR
Brown
20x60 cm - 30



C2020BR
Brown
20x20 cm - 2



W20BR
Matita jolly Brown
1,2x20 cm - O

FONDI LUCIDI - PLAIN TILES, GLOSS - ГЛЯНЦЕВАЯ ФОНОВАЯ ПЛИТКА



G2060CA
Calicanto
20x60 cm - 35



G2020CA
Calicanto
20x20 cm - 0



G20CA
Matita jolly Calicanto
1,2x20 cm - O



BE26WN
Beat Colore White-Narciso
20x60 cm - B

FONDI OPACHI - PLAIN TILES, MATTE - МАТОВАЯ ФОНОВАЯ ПЛИТКА

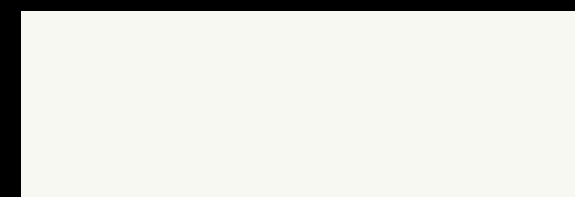

C2060W
White
20x60 cm - 30

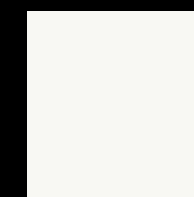

C2020W
White
20x20 cm - 2



W20W
Matita jolly White
1,2x20 cm - O

FONDI LUCIDI - PLAIN TILES, GLOSS - ГЛЯНЦЕВАЯ ФОНОВАЯ ПЛИТКА

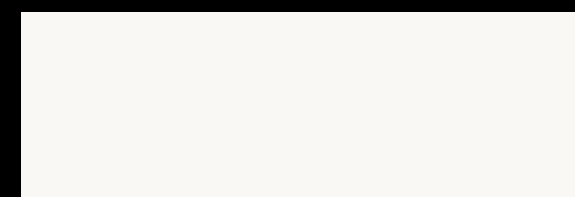

G2060NA
Narciso
20x60 cm - 35

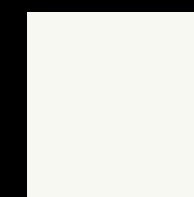

G2020NA
Narciso
20x20 cm - 0



G20NA
Matita jolly Narciso
1,2x20 cm - O



BE26EB
Beat Colore Elleboro-Black
20x60 cm - B

FONDI OPACHI - PLAIN TILES, MATTE - МАТОВАЯ ФОНОВАЯ ПЛИТКА

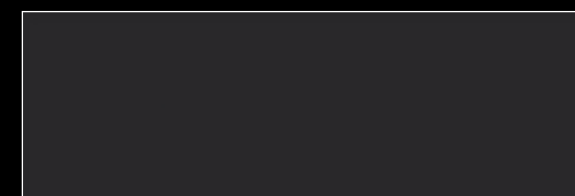

C2060BK
Black
20x60 cm - 30



C2020BK
Black
20x20 cm - 2



W20BK
Matita jolly Black
1,2x20 cm - O

FONDI LUCIDI - PLAIN TILES, GLOSS - ГЛЯНЦЕВАЯ ФОНОВАЯ ПЛИТКА

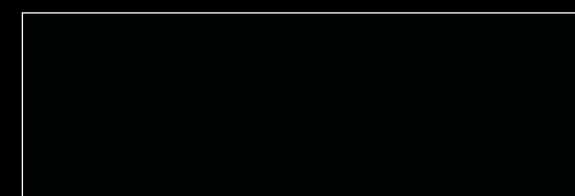

G2060EL
Elleboro
20x60 cm - 35

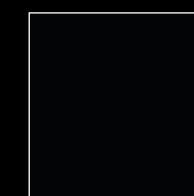

G2020EL
Elleboro
20x20 cm - 0



G20EL
Matita jolly Elleboro
1,2x20 cm - O

G80NA
Battiscopa
Narciso
20x60 cm - AO

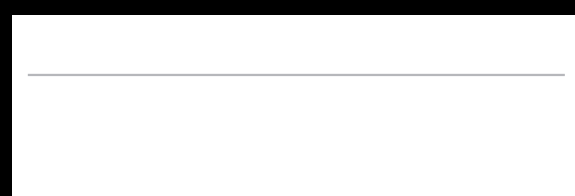

Sezione
battiscopa

G81NA
Angolo esterno
battiscopa
Narciso
2x20 cm - E



G80NAD
Battiscopa
Narciso smaltato
lato destro
20x60 cm - AQ

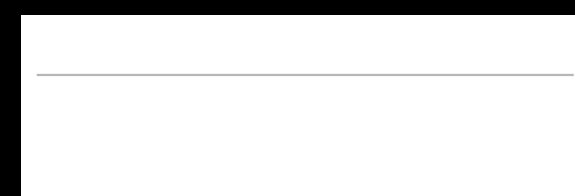

G80NAS
Battiscopa
Narciso smaltato
lato sinistro
20x60 cm - AQ



**BE26EGO**Beat Multicolore Edera-Green-Orchidea
20x60 cm - B

FONDI OPACHI - PLAIN TILES, MATTE - МАТОВАЯ ФОНОВАЯ ПЛИТКА

**C2060G**Green
20x60 cm - 30**C2020G**Green
20x20 cm - 2**W20G**Matita jolly Green
1,2x20 cm - 0

FONDI LUCIDI - PLAIN TILES, GLOSS - ГЛЯНЦЕВАЯ ФОНОВАЯ ПЛИТКА

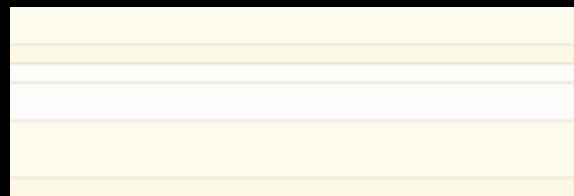
**G2060OC**Orchidea
20x60 cm - 35**G2020OC**Orchidea
20x20 cm - 0**G20OC**Matita jolly Orchidea
1,2x20 cm - 0**G2060ED**Edera
20x60 cm - 35**G2020ED**Edera
20x20 cm - 0**G20ED**Matita jolly Edera
1,2x20 cm - 0**BE26GBN**Beat Multicolore Gardenia-Beige-Narciso
20x60 cm - B

FONDI OPACHI - PLAIN TILES, MATTE - МАТОВАЯ ФОНОВАЯ ПЛИТКА

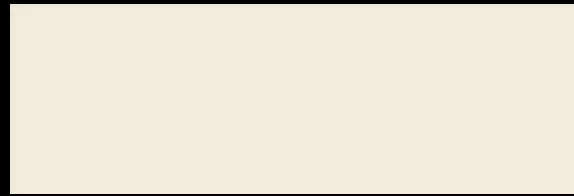
**C2060BE**Beige
20x60 cm - 30**C2020BE**Beige
20x20 cm - 2**W20BE**Matita jolly Beige
1,2x20 cm - 0

FONDI LUCIDI - PLAIN TILES, GLOSS - ГЛЯНЦЕВАЯ ФОНОВАЯ ПЛИТКА

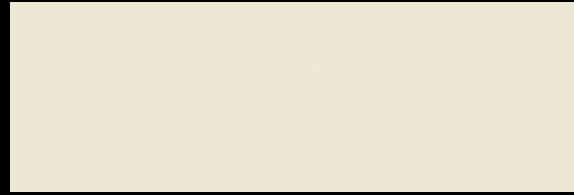
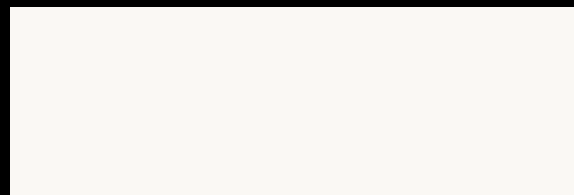
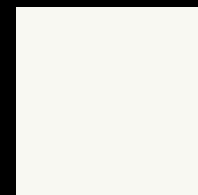
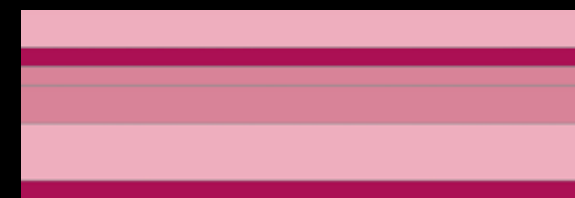
**G2060GA**Gardenia
20x60 cm - 35**G2020GA**Gardenia
20x20 cm - 0**G20GA**Matita jolly Gardenia
1,2x20 cm - 0**G2060NA**Narciso
20x60 cm - 35**G2020NA**Narciso
20x20 cm - 0**G20NA**Matita jolly Narciso
1,2x20 cm - 0**BE26CPN**Beat Multicolore Ciclamino-Pink-Ninfea
20x60 cm - B

FONDI OPACHI - PLAIN TILES, MATTE - МАТОВАЯ ФОНОВАЯ ПЛИТКА

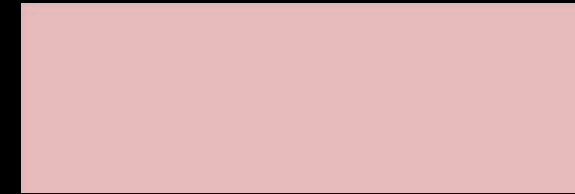
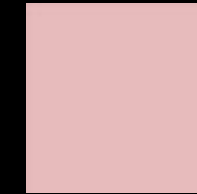
**C2060P**Pink
20x60 cm - 30**C2020P**Pink
20x20 cm - 2**W20P**Matita jolly Pink
1,2x20 cm - 0

FONDI LUCIDI - PLAIN TILES, GLOSS - ГЛЯНЦЕВАЯ ФОНОВАЯ ПЛИТКА

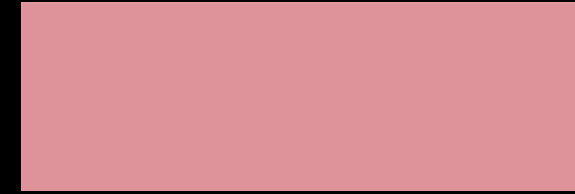
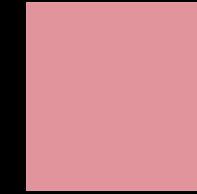
**G2060NI**Ninfea
20x60 cm - 35**G2020NI**Ninfea
20x20 cm - 0**G20NI**Matita jolly Ninfea
1,2x20 cm - 0**G2060CI**Ciclamino
20x60 cm - 35**G2020CI**Ciclamino
20x20 cm - 0**G20CI**Matita jolly Ciclamino
1,2x20 cm - 0**BE26DBO**Beat Multicolore Dalia-Blue-Ortensia
20x60 cm - B

FONDI OPACHI - PLAIN TILES, MATTE - МАТОВАЯ ФОНОВАЯ ПЛИТКА

**C2060BL**Blue
20x60 cm - 30**C2020BL**Blue
20x20 cm - 2**W20BL**Matita jolly Blue
1,2x20 cm - 0

FONDI LUCIDI - PLAIN TILES, GLOSS - ГЛЯНЦЕВАЯ ФОНОВАЯ ПЛИТКА

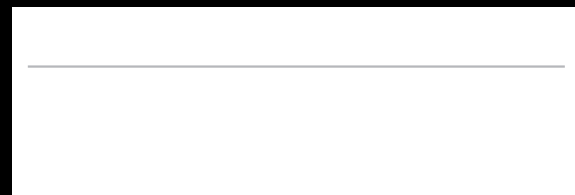
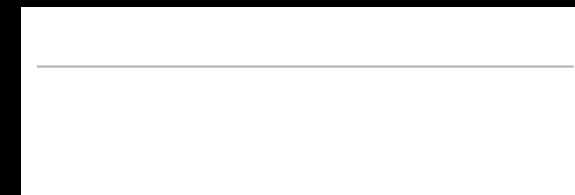
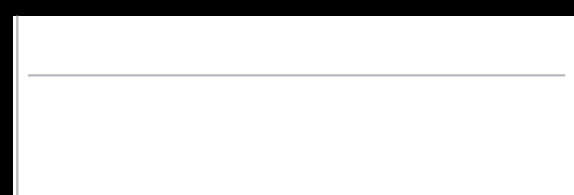
**G2060OR**Ortensia
20x60 cm - 35**G2020OR**Ortensia
20x20 cm - 0**G20OR**Matita jolly Ortensia
1,2x20 cm - 0**G2060DA**Dalia
20x60 cm - 35**G2020DA**Dalia
20x20 cm - 0**G20DA**Matita jolly Dalia
1,2x20 cm - 0**G80NA**Battiscopa
Narciso
20x60 cm - AOSezione
battiscopa**G81NA**Angolo esterno
battiscopa
Narciso
2x20 cm - E**G80NAD**Battiscopa
Narciso smaltato
lato destro
20x60 cm - AQ**G80NAS**Battiscopa
Narciso smaltato
lato sinistro
20x60 cm - AQ

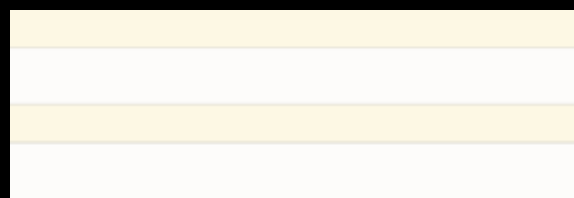

BE26GN
Beat Bicolore Gardenia-Narciso
20x60 cm - E

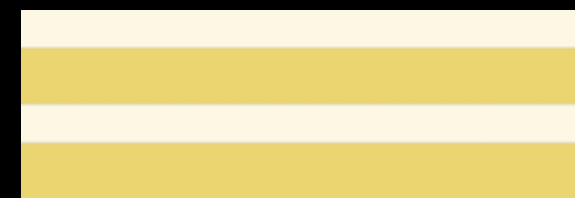

BE26GG
Beat Bicolore Gerbera-Gardenia
20x60 cm - E

FONDI LUCIDI - PLAIN TILES, GLOSS - ГЛЯНЦЕВАЯ ФОНОВАЯ ПЛИТКА

FONDI LUCIDI - PLAIN TILES, GLOSS - ГЛЯНЦЕВАЯ ФОНОВАЯ ПЛИТКА

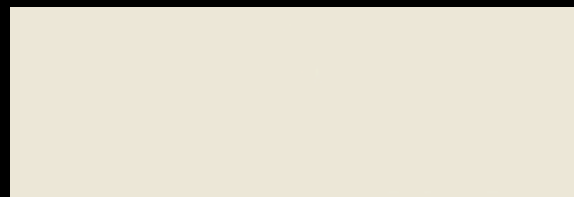

G2060GA
Gardenia
20x60 cm - 35



G2020GA
Gardenia
20x20 cm - 0



G20GA
Matita jolly Gardenia
1,2x20 cm - 0



G2060GE
Gerbera
20x60 cm - 35



G2020GE
Gerbera
20x20 cm - 0

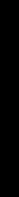

G20GE
Matita jolly Gerbera
1,2x20 cm - 0

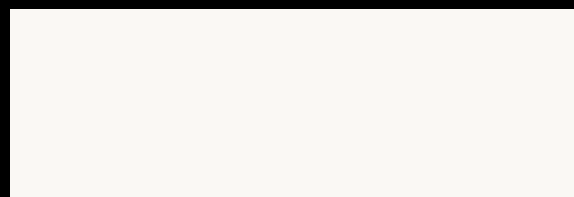

G2060NA
Narciso
20x60 cm - 35

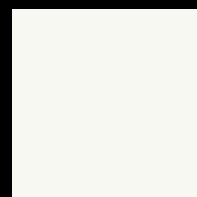

G2020NA
Narciso
20x20 cm - 0



G20NA
Matita jolly Narciso
1,2x20 cm - 0

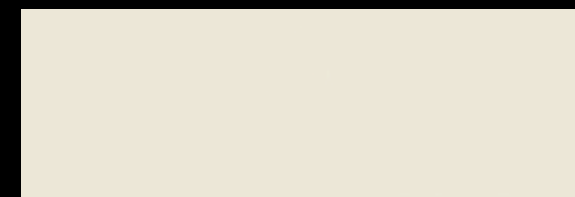

G2060GA
Gardenia
20x60 cm - 35



G2020GA
Gardenia
20x20 cm - 0

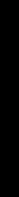

G20GA
Matita jolly Gardenia
1,2x20 cm - 0



BE26EN
Beat Bicolore Elleboro-Narciso
20x60 cm - E

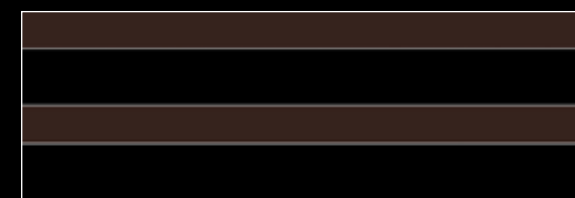

BE26EC
Beat Bicolore Elleboro-Calicanto
20x60 cm - E

FONDI LUCIDI - PLAIN TILES, GLOSS - ГЛЯНЦЕВАЯ ФОНОВАЯ ПЛИТКА

FONDI LUCIDI - PLAIN TILES, GLOSS - ГЛЯНЦЕВАЯ ФОНОВАЯ ПЛИТКА

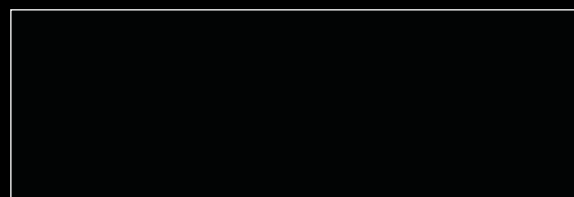

G2060EL
Elleboro
20x60 cm - 35



G2020EL
Elleboro
20x20 cm - 0



G20EL
Matita jolly Elleboro
1,2x20 cm - 0

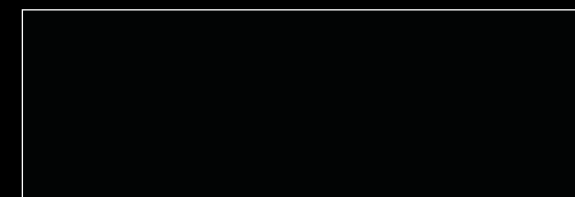

G2060EL
Elleboro
20x60 cm - 35

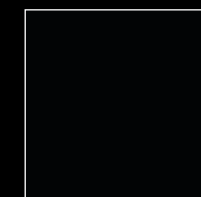

G2020EL
Elleboro
20x20 cm - 0

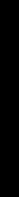

G20EL
Matita jolly Elleboro
1,2x20 cm - 0

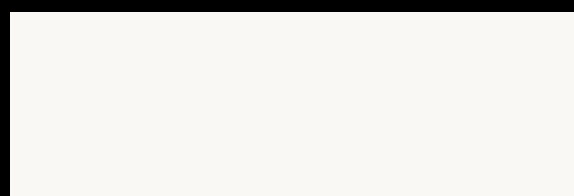

G2060NA
Narciso
20x60 cm - 35

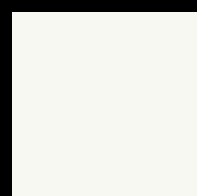

G2020NA
Narciso
20x20 cm - 0



G20NA
Matita jolly Narciso
1,2x20 cm - 0



G2060CA
Calicanto
20x60 cm - 35



G2020CA
Calicanto
20x20 cm - 0

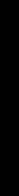

G20CA
Matita jolly Calicanto
1,2x20 cm - 0

G80NA
Battiscopa
Narciso
20x60 cm - AO

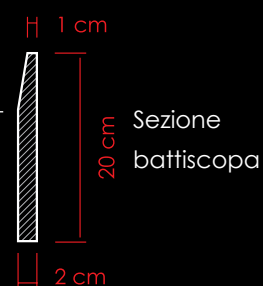
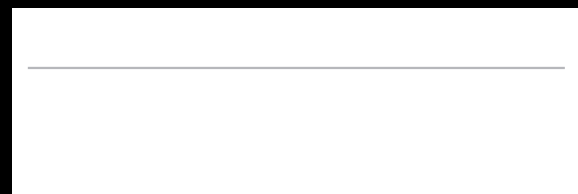

G81NA
Angolo esterno
battiscopa
Narciso
2x20 cm - E



G80NAD
Battiscopa
Narciso smaltato
lato destro
20x60 cm - AQ

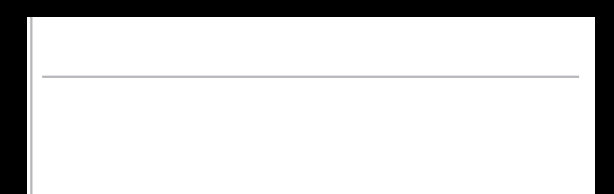

G80NAS
Battiscopa
Narciso smaltato
lato sinistro
20x60 cm - AQ



Lavabo da appoggio
Above top washbasin
НАСТОЛЬНЫЙ УМЫВАЛЬНИК



T50
 Lavabo
 50,5x50,5x14,5 cm

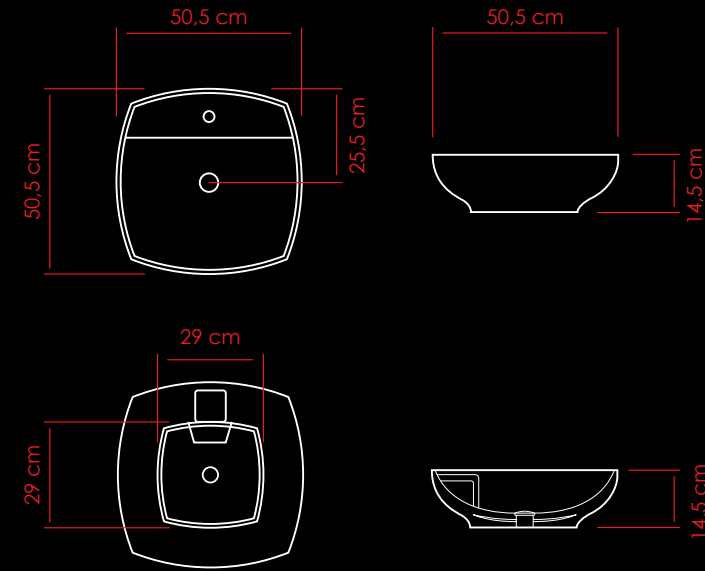

Lavabo sospeso con staffa di sostegno
Wall-mounted washbasin with bracket
Подвесной умывальник с опорным кронштейном



T50
 Lavabo
 50,5x50,5x14,5 cm

ST50
 Staffa di sostegno
 37x12 cm

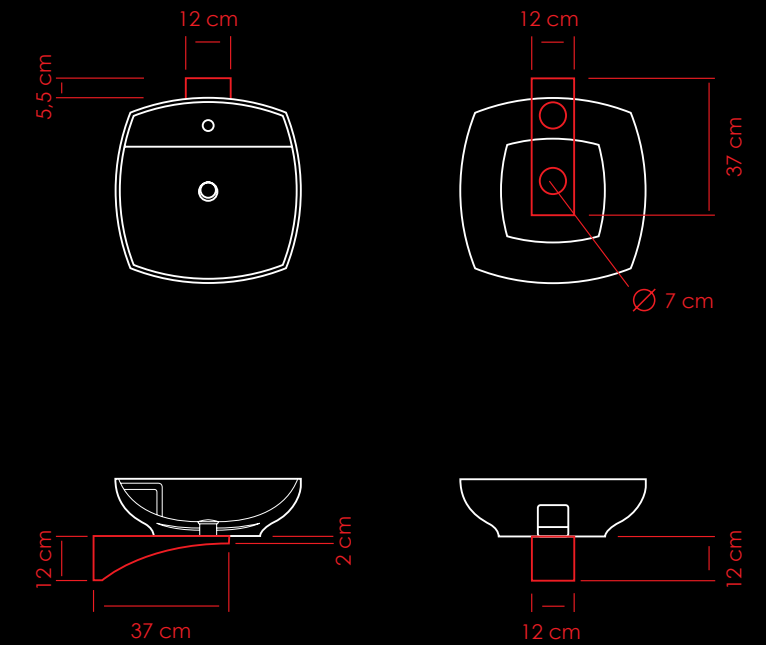

T80
 Lavabo
 52x81x14,5 cm

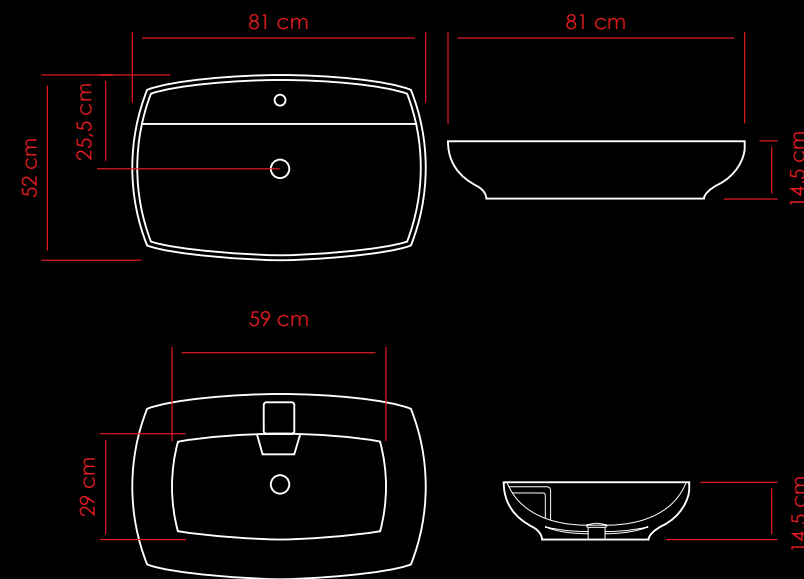

T80
 Lavabo
 52x81x14,5 cm

ST80
 Staffa di sostegno
 37x34 cm

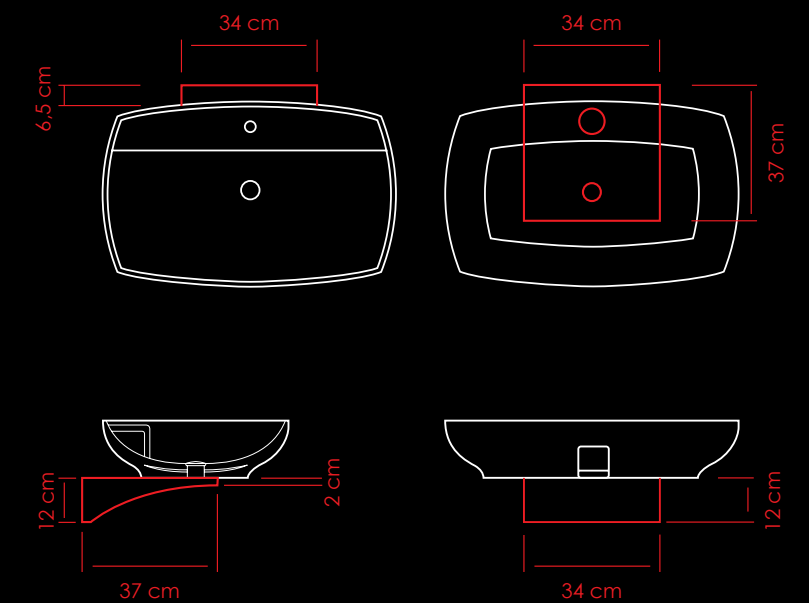



Vaso - WC - УНИТАЗ

TV
Vaso
38x54 cm

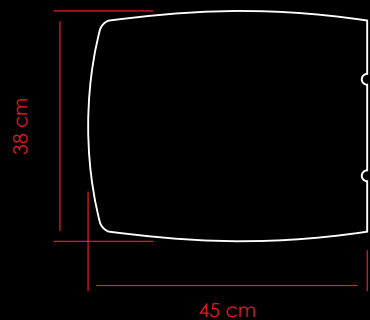
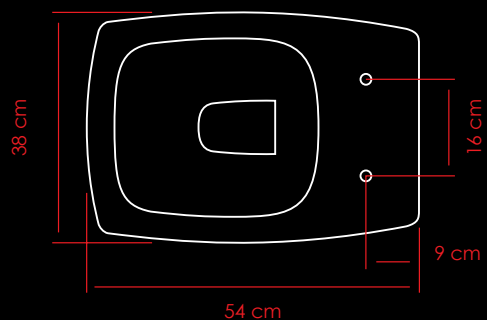

TC
Copri Vaso
con chiusura soft

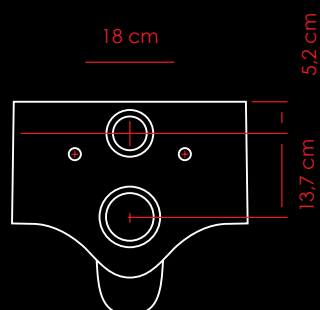
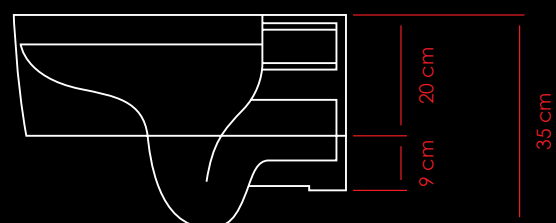

Bidet - Bidet - БИДЕ

TB
Bidet
38x54 cm

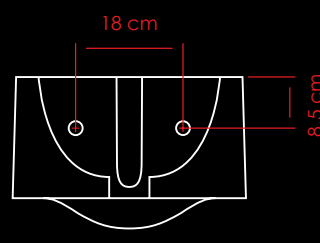
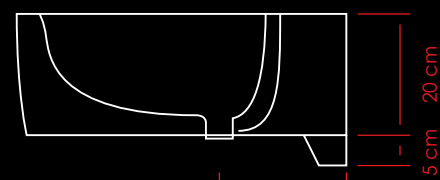
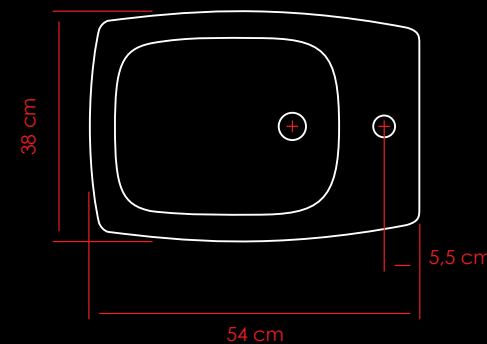

SCHEDA TECNICA

FONDI (Bicottura)

La lavorazione di questi fondi è articolata in più passaggi al fine di creare un prodotto ricercato e curato nel dettaglio. Alla cottura del cottoforte seguono varie lavorazioni: molteplici stratificazioni di smalti e cristalline che rendono il prodotto profondo ed estremamente morbido nella superficie. I fondi subiscono una lavorazione a doppio velo, un doppio passaggio di cristalline e smalti che permette di ottenere una profondità di prodotto unica.

FONDI OPACHI

In un metro quadrato sono presenti circa 3,0 kg di smalto e cristalline.

Successivamente a queste lavorazioni il prodotto subisce una ulteriore cottura a 1.050 gradi, nel quale lo smalto si fissa al supporto.

Piccole variazioni di lucentezza e di colore sulla superficie sono il risultato di lavorazioni artigianali che conferiscono pregio ed unicità ad ogni singola lavorazione

FONDI LUCIDI

In un metro quadrato sono presenti circa 3,2 kg di smalto e cristalline.

Successivamente a queste lavorazioni il prodotto subisce una ulteriore cottura a 1.050 gradi, nel quale lo smalto si fissa al supporto.

Piccoli fori e leggere imperfezioni in superficie sono il risultato della stesura consistente di smalto e delle successive lavorazioni ricercate.

Possibili effetti craquelè (cavillo) si possono presentare occasionalmente soprattutto dopo la posa, derivanti da sollecitazioni meccaniche di trazione sulla strato consistente di smalto. L'effetto non si presenta se non in rare condizioni.

I fondi lucidi ed opachi sono disponibili nei formati 20x20 e 20x60, entrambi in spessore 1 cm.

Si consiglia un uso del prodotto da interno, pavimento per ambienti bagno, rivestimento per qualsiasi ambiente.

ISTRUZIONI PER LA POSA E LA STUCCATURA DEL PRODOTTO

Inizialmente si deve procedere ad una corretta preparazione del sottofondo in modo che sia pulito, asciutto ed esente da umidità, senza crepe e non deve presentare dislivelli di planarità.

Si consiglia di utilizzare un adesivo monocomponente per piastrelle in ceramica a base cementizia ad alta adesione, buona deformabilità e scivolamento verticale nullo.

MAPEI KERAFLEX MAXI S1 - MAPEI ELASTORAPID
KERAKOLL SPECIAL - KERAKOLL H40 FLEX

Per fughe utilizzare stucco a grana fine, a ridotto assorbimento d'acqua, a presa ed asciugamento rapido.

MAPEI ULTRACOLOR PLUS (malta ad alte prestazioni, antiflorescenze, idrorepellente, a presa ed asciugamento rapido per la stuccatura di fughe da 2 a 20 mm)

KERAKOLL FUGABELLA PORCELANA 0-5 (stucco porcellanato fine professionale monocomponente a tecnologia microgranulare, elevata durezza, ridotto assorbimento d'acqua)

KERAKOLL FUGABELLA 2-12 (per le fughe da 2 a 12 mm stucco professionale monocomponente a finitura liscia calibrata, elevata durezza e ridotto assorbimento d'acqua)

Per le caratteristiche e le modalità d'impiego dei materiali indicati si rimanda alle relative schede tecniche.

La Decoratori Bassanesi S.r.l per nessun motivo accoglierà contestazioni sul materiale posato.

I colori di prodotti riportati nel presente catalogo sono puramente indicativi dei colori reali.

PRODUCT DATA SHEET

PLAIN TILES (double fired)

These tiles are manufactured by a process involving several stages, designed to produce a stylish and expertly crafted product. After firing, cottoforte undergoes a number of processing steps: several layers of glaze giving the product depth, and making it extremely soft to the touch.

Plain tiles undergo a dual layer process — two applications of glaze slips combining to produce a finish of unique depth and colour.

PLAIN TILES, MATTE:

One square metre of tiling contains around 3.0 kg of glaze and microcrystal.

Following the sequence of glazing steps, the tiles are fired for a second time at 1,050 degrees to anchor the glaze to the ceramic body.

Slight variations in surface brightness and colour are the result of traditional craft techniques by which every step of the process is rendered special and unique.

PLAIN TILES, GLOSS

One square metre of tiling contains around 3.2 kg of glaze and microcrystal.

Following the sequence of glazing steps, the tiles are fired for a second time at 1,050 degrees to anchor the glaze to the ceramic body.

Any pinholes and minor imperfections in the surface are quite normal, given the thickness of the glaze and the special process adopted.

Crazing may appear in the glaze, especially after the tiles have been bonded to the substrate, due likewise to the depth of the glaze and the mechanical stresses induced during installation. In practice however, this will rarely occur.

Plain tiles, gloss and matte are made in 20x20 and 20x60 sizes, both 1 cm thick.

Because the particular texture of the glaze are easily defaced, great care should be taken when handling and during installation.

The product is intended for internal use, typically on bathroom floors, and as a wall covering for any interior.

INSTRUCTIONS FOR INSTALLATION AND GROUTING

The first step is to ensure correct preparation of the substrate, which must be clean, dry, devoid of residual moisture and with no cracks. The surface must be perfectly flat.

For best results, select a ready-to-use cement-based tile adhesive with strong bonding properties, good flexibility and zero vertical slippage.

MAPEI KERAFLEX MAXI S1 - MAPEI ELASTORAPID
KERAKOLL SPECIAL - KERAKOLL H40 FLEX

Use a fine grade grouting cement with low water absorption, preferably fast-setting and fast-drying.

MAPEI ULTRACOLOR PLUS (high performance grouting mortar with efflorescence-inhibiting, water-repellent, fast-setting and fast-drying properties, for gaps of 2 to 20 mm)

KERAKOLL FUGABELLA PORCELANA 0-5 (ready-to-use professional vitreous grouting cement featuring microgranule technology; offers superior hardness and low water absorption)

KERAKOLL FUGABELLA 2-12 (ready-to-use professional grouting cement featuring smooth finish, superior hardness and low water absorption, for gaps of 2 to 12 mm)

For specifications and recommended use of the materials indicated, refer to the relative technical data sheets.

Decoratori Bassanesi S.r.l will under no circumstances accept complaints regarding material post-installation.

Actual product colours may differ from the colours shown in this catalogue, which are purely indicative.

ОДНОТОННАЯ ПЛИТКА (двукратного обжига)

Обработка однотонной плитки выполняется в несколько приемов с целью создания изысканной продукции с тщательно разработанными деталями.

За обжигом бисквита (коттофорте) следуют различные этапы обработки: наносятся многочисленные слои глазури, которые придают изделию глубину и чрезвычайную мягкость поверхности на ощупь.

Однотонная плитка подвергается обработке с т.н. двойным слоем, то есть двойной этап нанесения цветной глазури, благодаря которому достигается уникальная глубина изделия.

матовая фоновая плитка

На одном квадратном метре материала имеются прибл. 3,0 кг цветной глазури.

После данной обработки изделия еще раз обжигаются при температуре 1050 градусов, и на этом этапе глазурь закрепляется на основе.

Небольшие изменения блеска и цвета на поверхности являются результатом ручной обработки, придающей ценный и уникальный характер каждому отдельному этапу.

глянцевая фоновая плитка

На одном квадратном метре материала имеются прибл. 3,2 кг цветной и прозрачной глазури.

После данной обработки изделия еще раз обжигаются при температуре 1050 градусов, и на этом этапе глазурь закрепляется на основе.

Небольшие отверстия и легкие поверхностные дефекты являются результатом нанесения большого количества глазури и последующей сложной обработки.

Возможный эффект кракелюры (трещинок) может возникнуть в любое время, особенно после укладки, в связи с механической тягой на толстый слой глазури. Этот эффект появляется очень редко.

глянцевая и матовая фоновая плитка Форматы однотонной плитки – 20x20 и 20x60 см, толщина обоих форматов составляет 1 см.

Данную продукцию рекомендуется использовать в помещениях, для

настила полов в ванных комнатах, или же для облицовки стен в любых других помещениях.

ИНСТРУКЦИЯ ПО УКЛАДКЕ ИЗДЕЛИЙ И ЗАДЕЛЫВАНИЮ ШВОВ

Сначала необходимо правильно подготовить подстилающий слой, который должен быть чистым, сухим и без следов влаги, без трещин и перепадов уровня.

Рекомендуем использовать однокомпонентный клей для керамической плитки на цементной основе с высокой склеивающей способностью, хорошей деформируемостью и нулевым вертикальным скольжением.

MAPEI KERAFLEX MAXI S1 - MAPEI ELASTORAPID KERAKOLL SPECIAL – KERAKOLL H40 FLEX

Для швов использовать затирку с мелкой зернистостью, с пониженным поглощением воды, быстросхватывающуюся и быстро сохнущую.

MAPEI ULTRACOLOR PLUS (затирка с высокими характеристиками, не образующая налеты, водоотталкивающая, быстросхватывающаяся и быстро сохнущая для заделки швов толщиной от 2 до 20 мм).

KERAKOLL FUGABELLA PORCELANA 0-5 (однокомпонентная тонкая фарфоровая затирка для профессионального применения, с микрогранулами, повышенной твердостью и умеренным поглощением воды).

KERAKOLL FUGABELLA 2-12 (для швов толщиной от 2 до 12 мм. Это однокомпонентная затирка для профессионального применения с гладкой калиброванной отделкой, повышенной твердостью и умеренным поглощением воды).

Характеристики и способ применения указанных материалов смотри в соответствующих технических характеристиках.

Компания Decoratori Bassanesi S.r.l. ни в коем случае не принимает претензии по уложенному материалу.

Указанные в настоящем каталоге цвета продукции являются лишь только ориентировочными по сравнению с фактическими.

Cartella colori stucchi

Si suggerisce di utilizzare per ogni colore di fondo lo stucco in coordinato riportato nella cartella

Grout colour chart

It is advisable to use the matching grout for each colour of plain tile, as indicated in the chart

цветовая гамма затирки

для каждого цвета однотонной плитки рекомендуем использовать сочетающуюся затирку, указанную в цветовой гамме

white	Mapei Ultracolor Plus n° 100	Kerakoll Fugabella Porcelana n° 01
beige	Mapei Ultracolor Plus n° 100	Kerakoll Fugabella Porcelana n° 01
brown	Mapei Ultracolor Plus n° 144	Kerakoll Fugabella Porcelana n° 12
black	Mapei Ultracolor Plus n° 120	Kerakoll Fugabella Porcelana n° 05
pink	Mapei Ultracolor Plus n° 140	Kerakoll Fugabella Porcelana n° 25
blue	Mapei Ultracolor Plus n° 110	Kerakoll Fugabella Porcelana n° 02
green	Mapei Ultracolor Plus n° 112	Kerakoll Fugabella Porcelana n° 03



Decoratori Bassanesi srl

Sede legale: Largo Perlasca, 19 - 36061 Bassano del Grappa (VI)
Uffici e deposito: Via Vallina Orticella, 48 - 31030 Borso del Grappa (TV)
Tel. 0423 910076 - Fax 0423 561188
info@decoratoristyle.it - www.decoratoristyle.it