

Collezione String

"Il fascino suggestivo della Francia degli anni '40
e la realizzazione di superfici ceramiche lucidissime
prodotte dalla tecnica affinata da esperti ceramisti"

"The evocative atmosphere of France in the 'Forties,
and the creation of high gloss tiled surfaces
by expert ceramic designers"

Заманчивое очарование Франции 40-х
годов и создание сверх-глянцевых керамических поверхностей,
получаемых изысканными методами мастеров керамического дела.

Carlo Dal Bianco







N60NI
String Ninfea
20x60 cm - 45



N20NI
String Ninfea
20x20 cm - 30



N60CI
String Ciclamino
20x60 cm - 45



N20CI
String Ciclamino
20x20 cm - 30

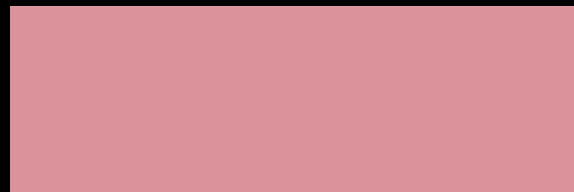

G2060NI
Ninfea
20x60 cm - 35



G2020NI
Ninfea
20x20 cm - 0

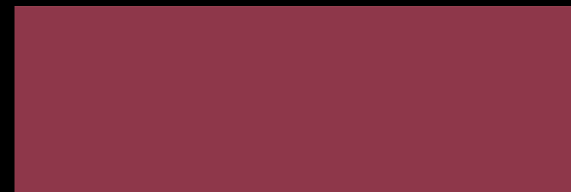

G2060CI
Ciclamino
20x60 cm - 35



G2020CI
Ciclamino
20x20 cm - 0

G20NI
Matita jolly Ninfea
1,2x20 cm - 0

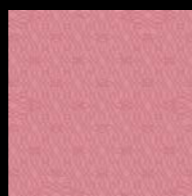

P2020NI
Intreccio Ninfea
20x20 cm - 25

G20CI
Matita jolly Ciclamino
1,2x20 cm - 0



P2020CI
Intreccio Ciclamino
20x20 cm - 25



G80NA
Battiscopa Narciso
20x60 cm - AQ

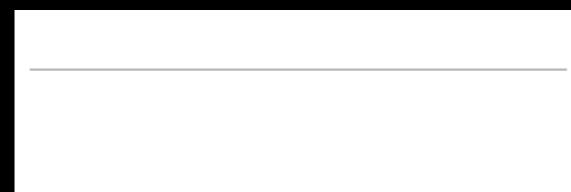

G80NAD
Battiscopa Narciso
smaltato lato destro
20x60 cm - AQ



G81NA
Angolo esterno
battiscopa Narciso
2x20 cm - E

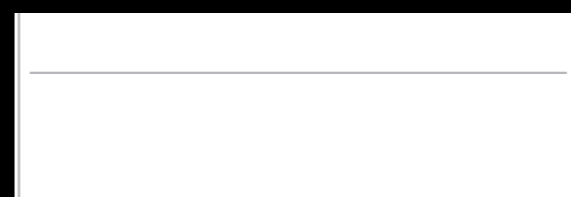

G80NAS
Battiscopa Narciso
smaltato lato sinistro
20x60 cm - AQ









N60OR
String Ortensia
20x60 cm - 45



N20OR
String Ortensia
20x20 cm - 30



N60DA
String Dalia
20x60 cm - 45



N20DA
String Dalia
20x20 cm - 30



G2060OR
Ortensia
20x60 cm - 35



G2020OR
Ortensia
20x20 cm - 0



G2060DA
Dalia
20x60 cm - 35



G2020DA
Dalia
20x20 cm - 0

G20OR
Matita jolly Ortensia
1,2x20 cm - 0

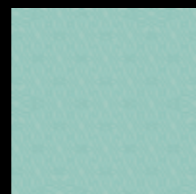

P2020OR
Intreccio Ortensia
20x20 cm - 25

G20DA
Matita jolly Dalia
1,2x20 cm - 0



P2020DA
Intreccio Dalia
20x20 cm - 25

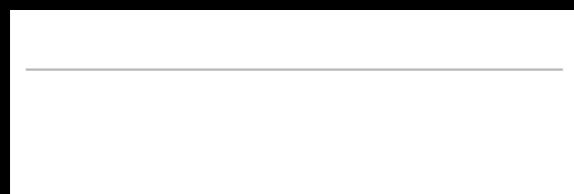

G80NA
Battiscopa Narciso
20x60 cm - AQ

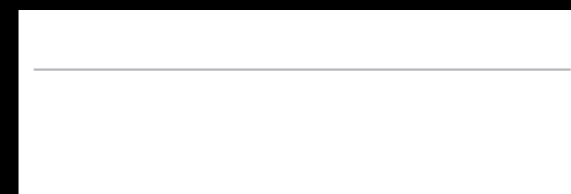

G80NAD
Battiscopa Narciso
smaltato lato destro
20x60 cm - AQ



G81NA
Angolo esterno
battiscopa Narciso
2x20 cm - E

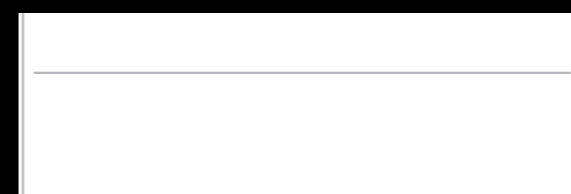

G80NAS
Battiscopa Narciso
smaltato lato sinistro
20x60 cm - AQ

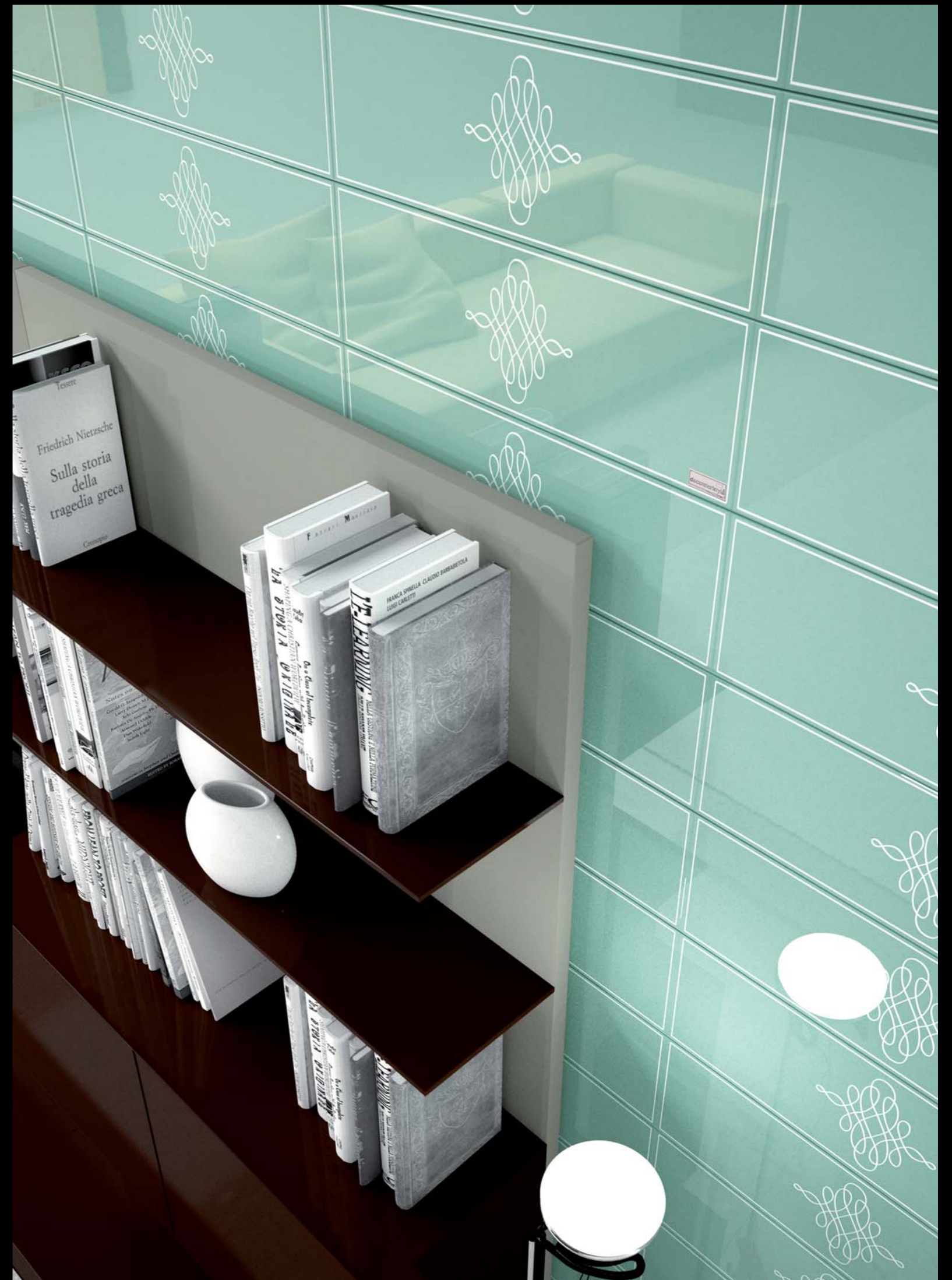











N60OC
String Orchidea
20x60 cm - 45



N20OC
String Orchidea
20x20 cm - 30

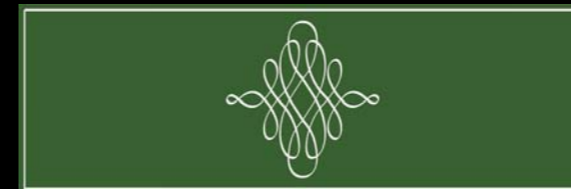

N60ED
String Edera
20x60 cm - 45



N20ED
String Edera
20x20 cm - 30



G2060OC
Orchidea
20x60 cm - 35



G2020OC
Orchidea
20x20 cm - 0



G2060ED
Edera
20x60 cm - 35



G2020ED
Edera
20x20 cm - 0

G20OC
Matita jolly Orchidea
1,2x20 cm - 0



P2020OC
Intreccio Orchidea
20x20 cm - 25

G20ED
Matita jolly Edera
1,2x20 cm - 0

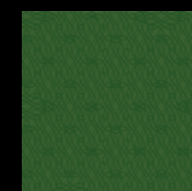

P2020ED
Intreccio Edera
20x20 cm - 25

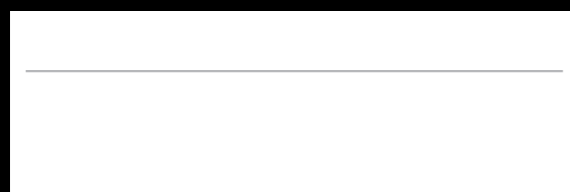

G80NA
Battiscopa Narciso
20x60 cm - AQ

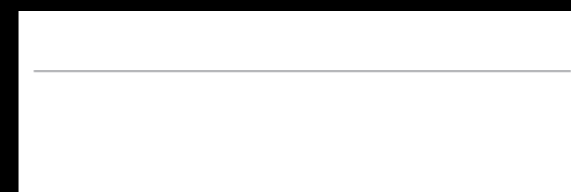

G80NAD
Battiscopa Narciso
smaltato lato destro
20x60 cm - AQ



G81NA
Angolo esterno
battiscopa Narciso
2x20 cm - E



G80NAS
Battiscopa Narciso
smaltato lato sinistro
20x60 cm - AQ



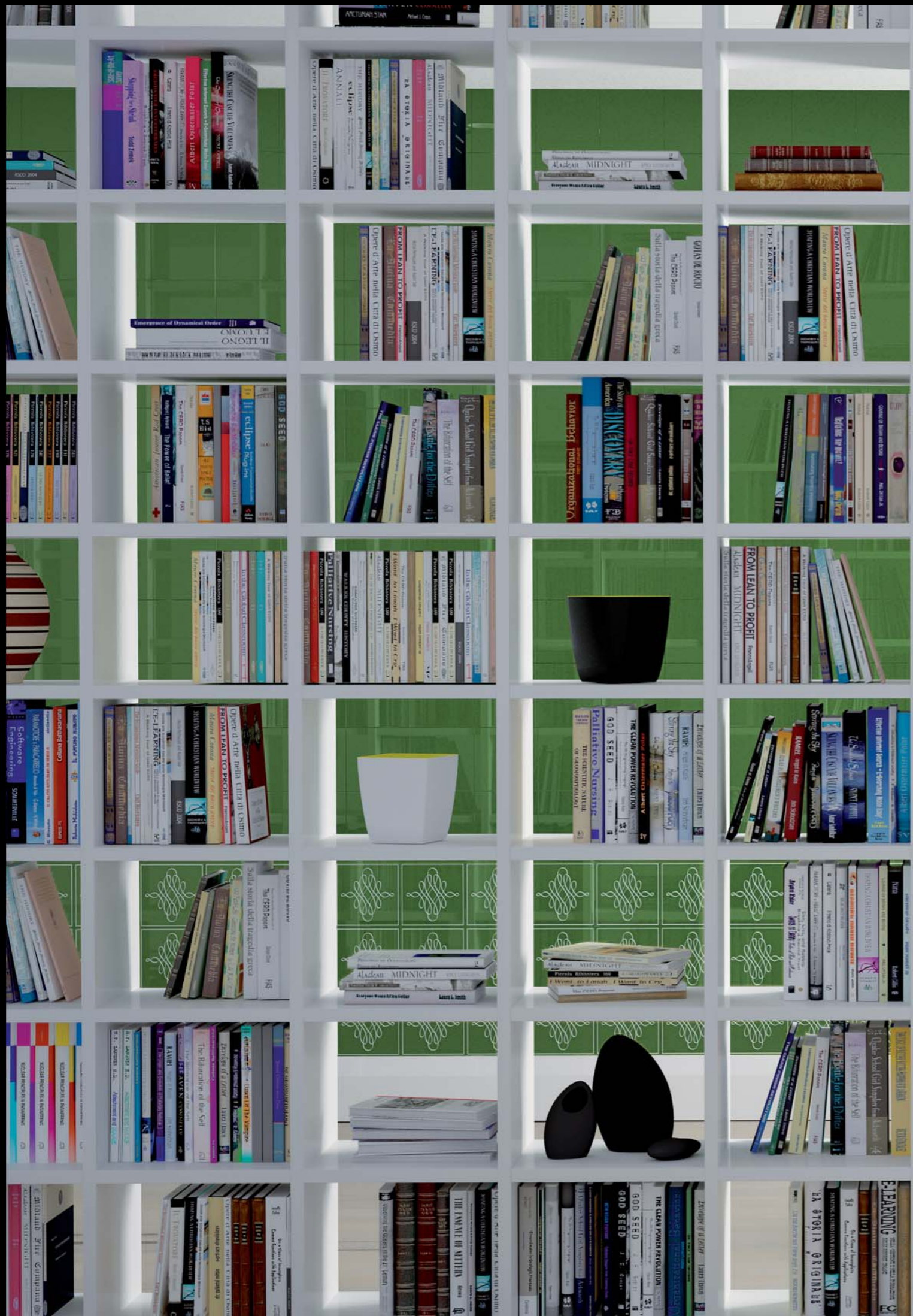







N60NA
String Narciso
20x60 cm - 45



N20NA
String Narciso
20x20 cm - 30



N60GA
String Gardenia
20x60 cm - 45



N20GA
String Gardenia
20x20 cm - 30

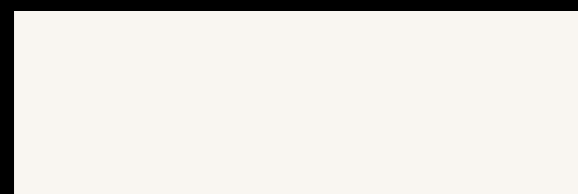

G2060NA
Narciso
20x60 cm - 35



G2020NA
Narciso
20x20 cm - 0

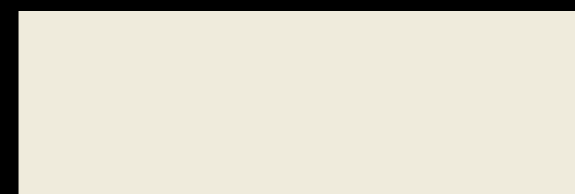

G2060GA
Gardenia
20x60 cm - 35



G2020GA
Gardenia
20x20 cm - 0

G20NA
Mafita jolly Narciso
1,2x20 cm - 0



P2020NA
Intreccio Narciso
20x20 cm - 25

G20GA
Mafita jolly Gardenia
1,2x20 cm - 0

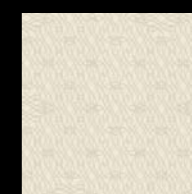

P2020GA
Intreccio Gardenia
20x20 cm - 25

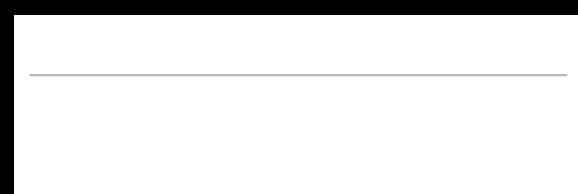

G80NA
Battiscopa Narciso
20x60 cm - AO

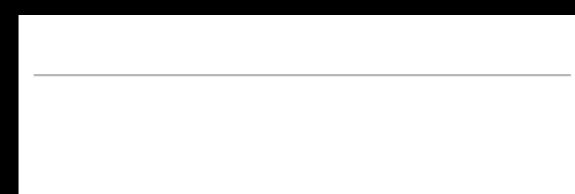

G80NAD
Battiscopa Narciso
smaltato lato destro
20x60 cm - AQ



G81NA
Angolo esterno
battiscopa Narciso
2x20 cm - E

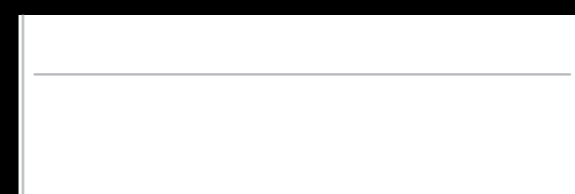

G80NAS
Battiscopa Narciso
smaltato lato sinistro
20x60 cm - AQ



Conclay. If G is a group then
the set $\text{Aut } G$ of automorphisms
of G form a group under composition

If A is a \mathbb{Z} -module $\text{Aut}(A) \subseteq \text{End}(A)$
 $\text{Aut}(A) = \text{End}(A)$
 $\text{Aut}(\mathbb{Z}) = (\text{End } \mathbb{Z})^{\times} \cong \mathbb{Z}^{\times}$
 $= \{1, -1\}$
 $\text{GL}(V) = \text{End}(V)^{\times}$

HW. Find $\text{End}(\mathbb{Z} \times \mathbb{Z})$
 $\text{Aut}(\mathbb{Z} \times \mathbb{Z})$
Find $\text{Aut}(\text{Sym}(\mathbb{Z}))$
Find $\text{Aut}(\mathbb{Q})$, $\text{End}(\mathbb{Q})$
Find $\text{Aut}(\mathbb{Q}^{\times})$, $\text{End}(\mathbb{Q}^{\times})$
Show that if
 $G = H$ then $\text{Aut } G \cong \dots$

$\psi(x)$









N60GE
String Gerbera
20x60 cm - 45



N20GE
String Gerbera
20x20 cm - 30



N60CA
String Calicanto
20x60 cm - 45



N20CA
String Calicanto
20x20 cm - 30



G2060GE
Gerbera
20x60 cm - 35



G2020GE
Gerbera
20x20 cm - 0



G2060CA
Calicanto
20x60 cm - 35



G2020CA
Calicanto
20x20 cm - 0

G20GE
Matita jolly Gerbera
1,2x20 cm - 0



P2020GE
Intreccio Gerbera
20x20 cm - 25

G20CA
Matita jolly Calicanto
1,2x20 cm - 0



P2020CA
Intreccio Calicanto
20x20 cm - 25

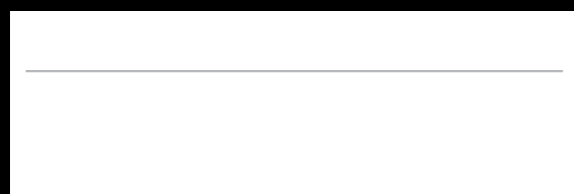

G80NA
Battiscopa Narciso
20x60 cm - AQ

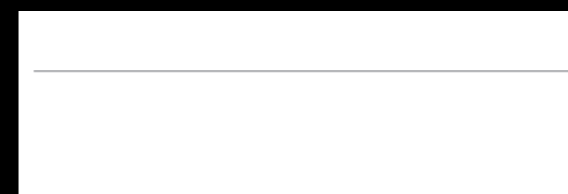

G80NAD
Battiscopa Narciso
smaltato lato destro
20x60 cm - AQ



G81NA
Angolo esterno
battiscopa Narciso
2x20 cm - E

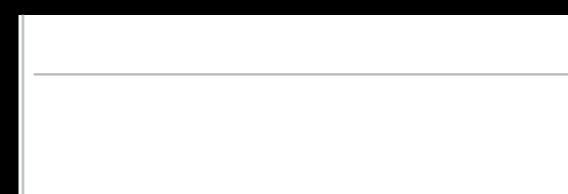

G80NAS
Battiscopa Narciso
smaltato lato sinistro
20x60 cm - AQ

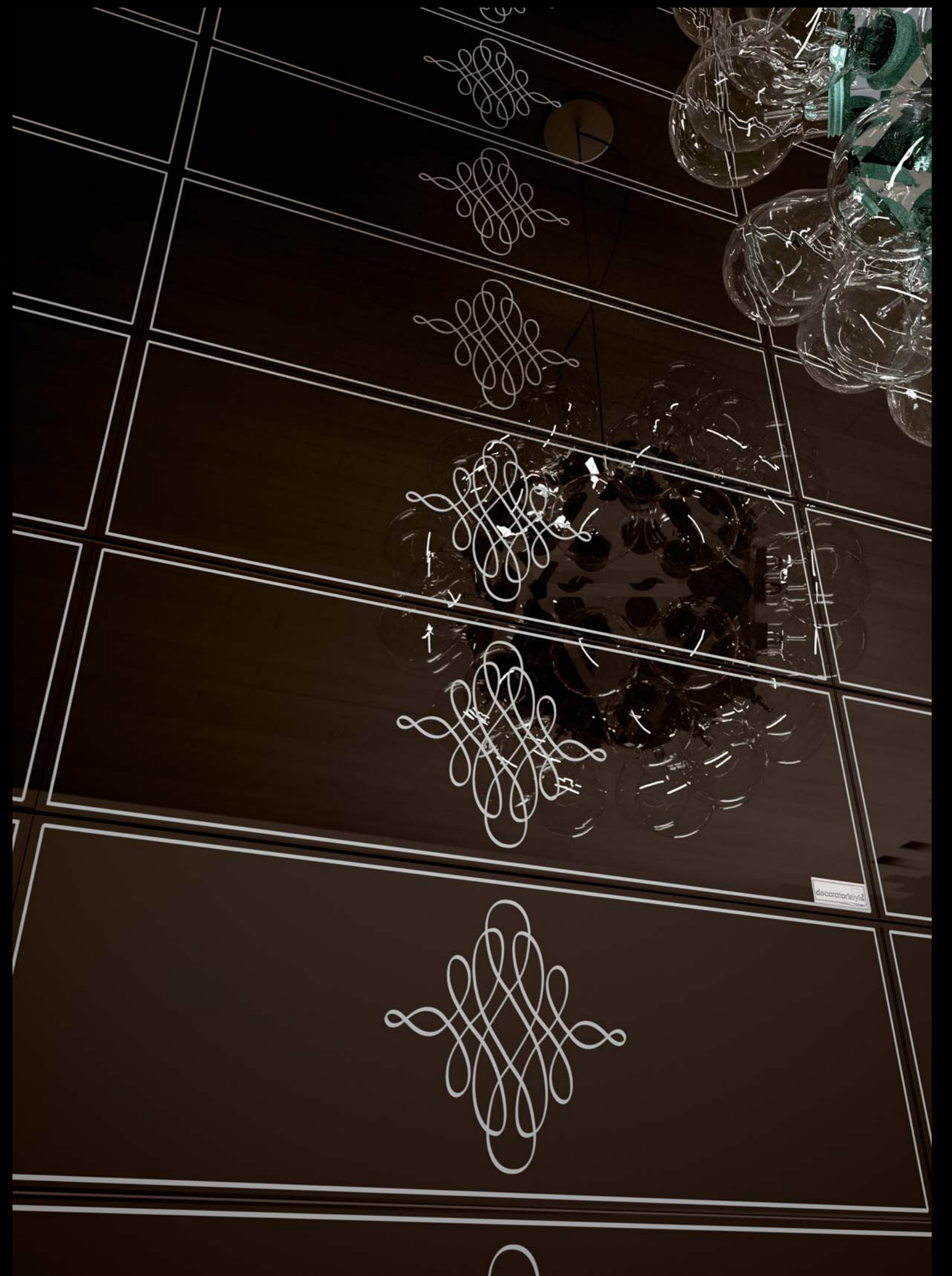









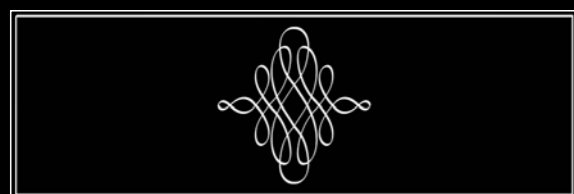

N60EL
String Elleboro
20x60 cm - 45



N20EL
String Elleboro
20x20 cm - 30

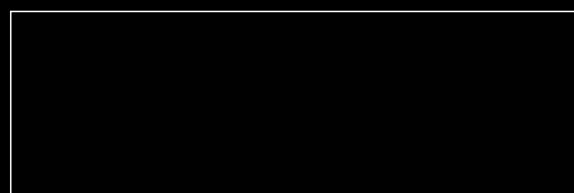

G2060EL
Elleboro
20x60 cm - 35

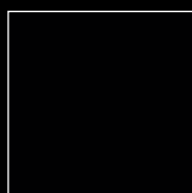

G2020EL
Elleboro
20x20 cm - 0



G20EL
Matita jolly Elleboro
1,2x20 cm - 0



P2020EL
Intreccio Elleboro
20x20 cm - 25

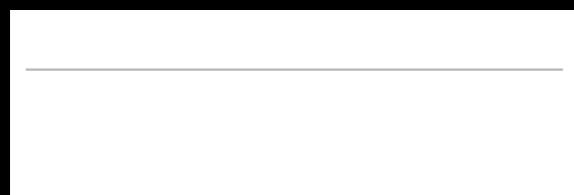

G80NA
Battiscopa Narciso
20x60 cm - AQ

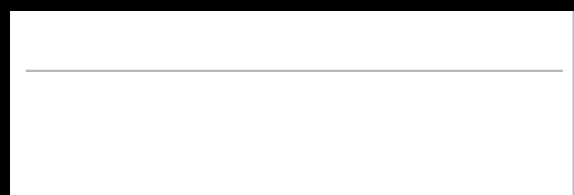

G80NAD
Battiscopa Narciso
smaltato lato destro
20x60 cm - AQ

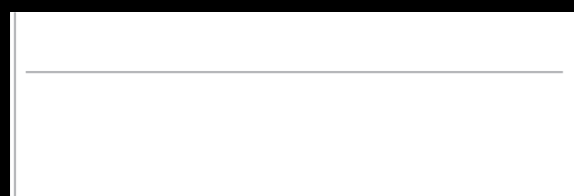

G80NAS
Battiscopa Narciso
smaltato lato sinistro
20x60 cm - AQ



G81NA
Angolo esterno
battiscopa Narciso
2x20 cm - E

String

Area Tecnica
Technical section
ТЕХНИЧЕСКИЙ РАЗДЕЛ



N60NI
String Ninfea
20x60 cm - 45



N20NI
String Ninfea
20x20 cm - 30

G20NI
Matita jolly
Ninfea
1,2x20 cm - 0

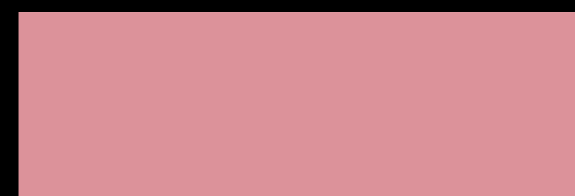

G2060NI
Ninfea
20x60 cm - 35

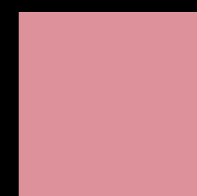

G2020NI
Ninfea
20x20 cm - 0



P2020NI
Intreccio
Ninfea
20x20 cm - 25



N60CI
String Ciclamino
20x60 cm - 45



N20CI
String Ciclamino
20x20 cm - 30

G20CI
Matita jolly
Ciclamino
1,2x20 cm - 0



G2060CI
Ciclamino
20x60 cm - 35



G2020CI
Ciclamino
20x20 cm - 0

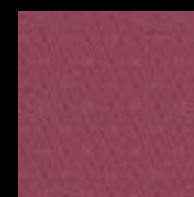

P2020CI
Intreccio
Ciclamino
20x20 cm - 25



N60OR
String Ortensia
20x60 cm - 45



N20OR
String Ortensia
20x20 cm - 30

G20OR
Matita jolly
Ortensia
1,2x20 cm - 0



G2060OR
Ortensia
20x60 cm - 35



G2020OR
Ortensia
20x20 cm - 0



P2020OR
Intreccio
Ortensia
20x20 cm - 25



N60DA
String Dalia
20x60 cm - 45



N20DA
String Dalia
20x20 cm - 30

G20DA
Matita jolly
Dalia
1,2x20 cm - 0



G2060DA
Dalia
20x60 cm - 35



G2020DA
Dalia
20x20 cm - 0



P2020DA
Intreccio
Dalia
20x20 cm - 25



N60OC
String Orchidea
20x60 cm - 45



N20OC
String Orchidea
20x20 cm - 30

G20OC
Matita jolly
Orchidea
1,2x20 cm - 0



G2060OC
Orchidea
20x60 cm - 35



G2020OC
Orchidea
20x20 cm - 0



P2020OC
Intreccio
Orchidea
20x20 cm - 25

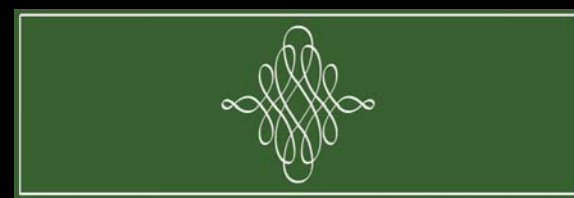

N60ED
String Edera
20x60 cm - 45

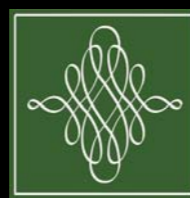

N20ED
String Edera
20x20 cm - 30

G20ED
Matita jolly
Edera
1,2x20 cm - 0



G2060ED
Edera
20x60 cm - 35



G2020ED
Edera
20x20 cm - 0



P2020ED
Intreccio
Edera
20x20 cm - 25



N60NA
String Narciso
20x60 cm - 45



N20NA
String Narciso
20x20 cm - 30

G20NA
Matita jolly
Narciso
1,2x20 cm - O

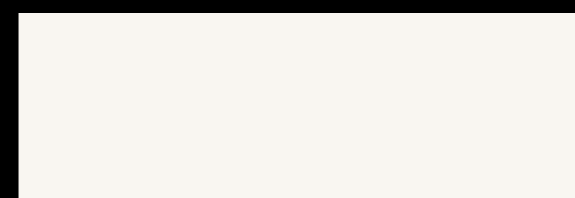

G2060NA
Narciso
20x60 cm - 35



G2020NA
Narciso
20x20 cm - 0



P2020NA
Intreccio
Narciso
20x20 cm - 25



N60GA
String Gardenia
20x60 cm - 45



N20GA
String Gardenia
20x20 cm - 30

G20GA
Matita jolly
Gardenia
1,2x20 cm - O

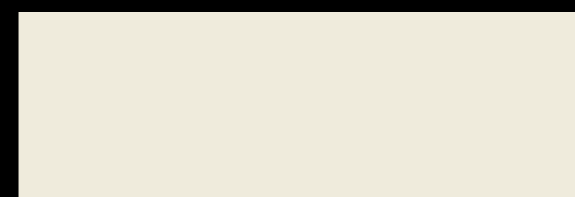

G2060GA
Gardenia
20x60 cm - 35



G2020GA
Gardenia
20x20 cm - 0

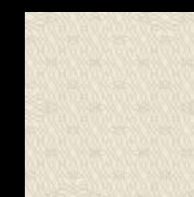

P2020GA
Intreccio
Gardenia
20x20 cm - 25



N60GE
String Gerbera
20x60 cm - 45



N20GE
String Gerbera
20x20 cm - 30

G20GE
Matita jolly
Gerbera
1,2x20 cm - O



G2060GE
Gerbera
20x60 cm - 35



G2020GE
Gerbera
20x20 cm - 0

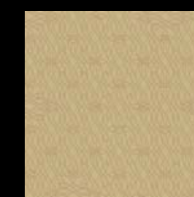

P2020GE
Intreccio
Gerbera
20x20 cm - 25



N60CA
String Calicanto
20x60 cm - 45



N20CA
String Calicanto
20x20 cm - 30

G20CA
Matita jolly
Calicanto
1,2x20 cm - O



G2060CA
Calicanto
20x60 cm - 35



G2020CA
Calicanto
20x20 cm - 0



P2020CA
Intreccio
Calicanto
20x20 cm - 25

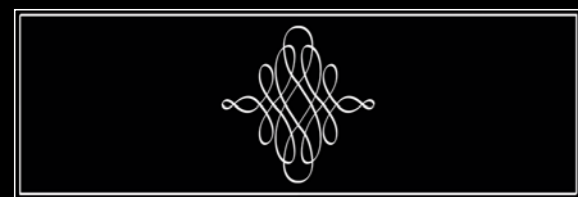

N60EL
String Elleboro
20x60 cm - 45



N20EL
String Elleboro
20x20 cm - 30

G20EL
Matita jolly
Elleboro
1,2x20 cm - O

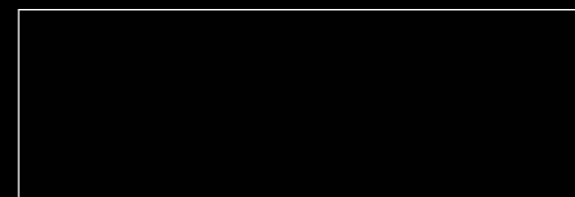

G2060EL
Elleboro
20x60 cm - 35

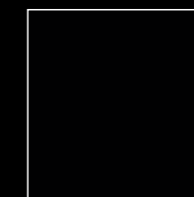

G2020EL
Elleboro
20x20 cm - 0



P2020EL
Intreccio
Elleboro
20x20 cm - 25

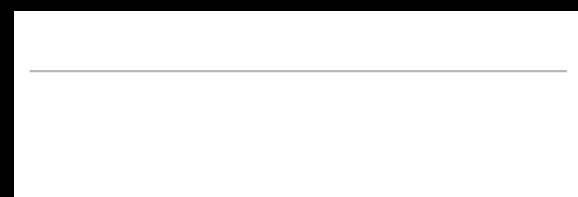

G80NA
Battiscopa
Narciso
20x60 cm - AO

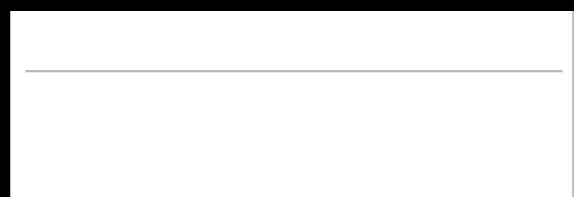

G80NAD
Battiscopa
Narciso smaltato
lato destro
20x60 cm - AQ



MARCHION26
Marchio
20x60 cm - F



MARCHION22
Marchio
20x20 cm - H

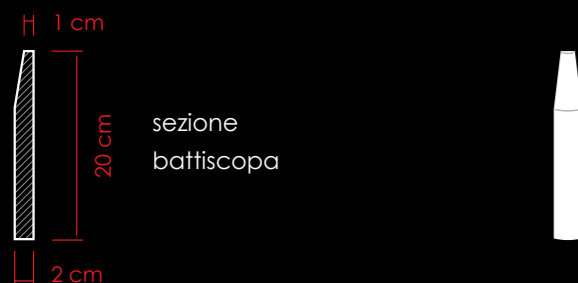

G81NA
Angolo esterno
battiscopa
Narciso
2x20 cm - E

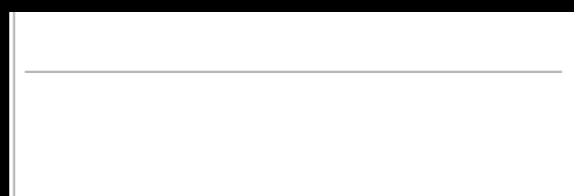

G80NAS
Battiscopa
Narciso smaltato
lato sinistro
20x60 cm - AQ



MARCHIO26
Marchio
20x60 cm - L

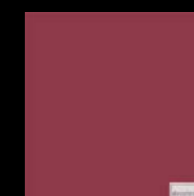

MARCHIO22
Marchio
20x20 cm - N



MARCHIO DECORATORISTYLE. Il marchio è disponibile in tutte le varianti colore.
MARCHIO DECORATORISTYLE. The logo file is available in all colour variations.
MARCHIO DECORATORISTYLE. Плитка с маркой выпускается всех цветов

View 22/xii/07

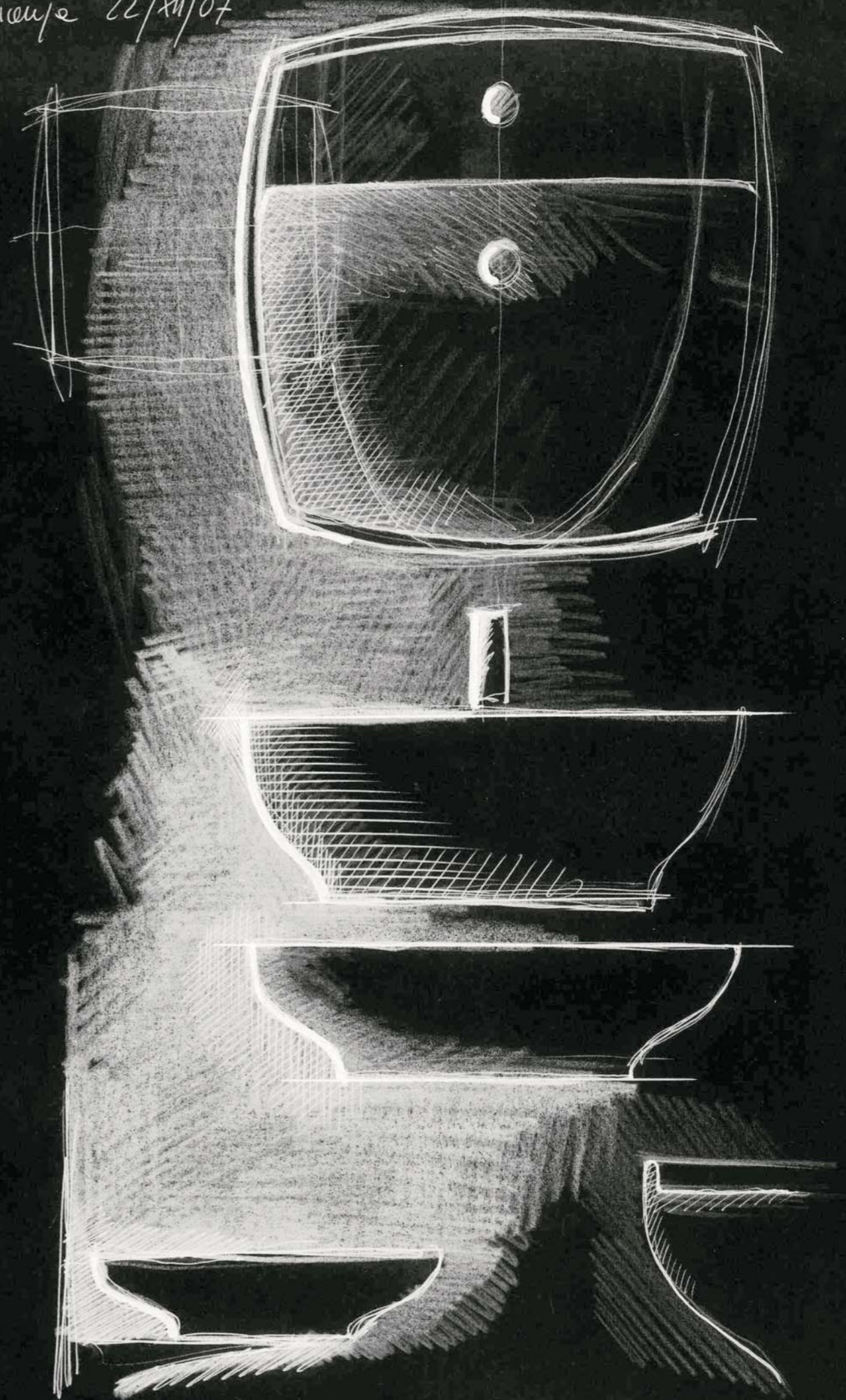

Carlo Cellini

Lavabo da appoggio
Above top washbasin
НАСТОЛЬНЫЙ УМЫВАЛЬНИК



T50
 Lavabo String
 50,5x50,5x14,5 cm

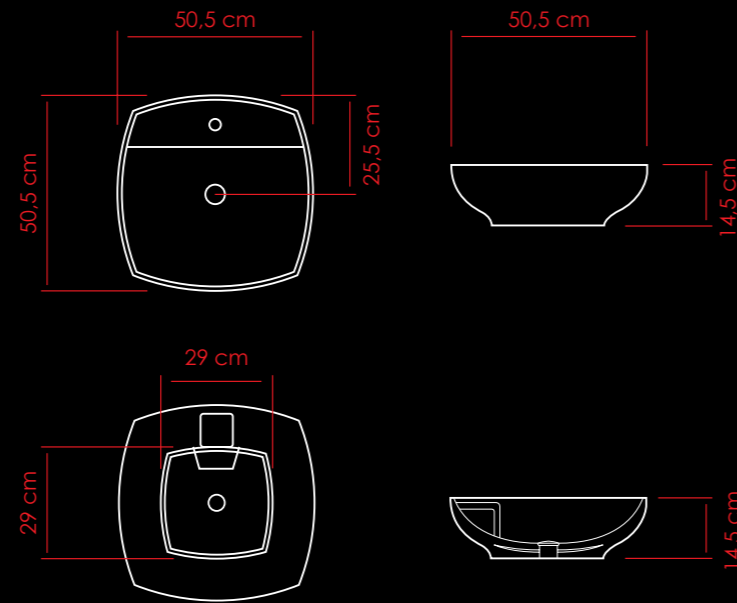

Lavabo sospeso con staffa di sostegno
Wall-mounted washbasin with bracket
Подвесной умывальник с опорным кронштейном



T50
 Lavabo String
 50,5x50,5x14,5 cm

ST50
 Staffa di sostegno
 37x12 cm

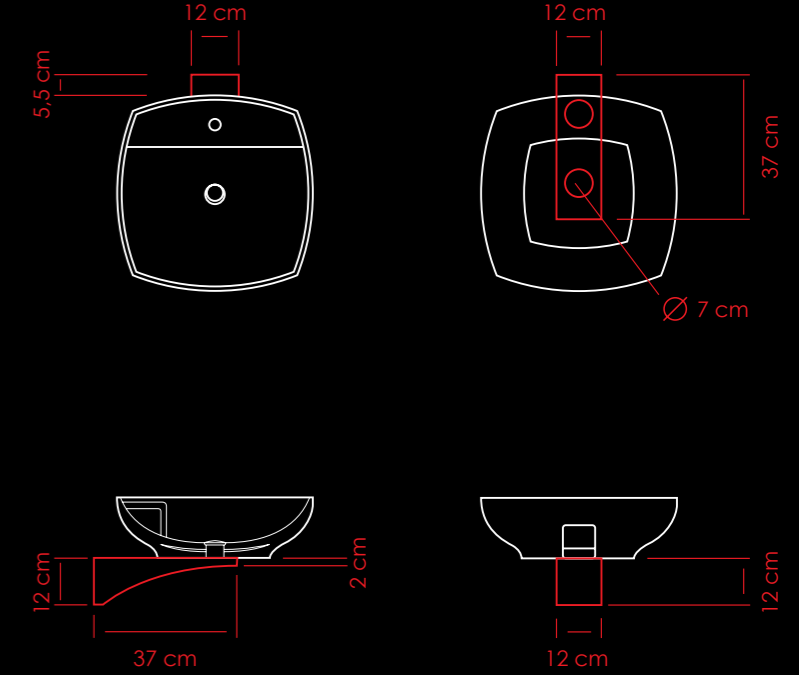

T80
 Lavabo String
 52x81x14,5 cm

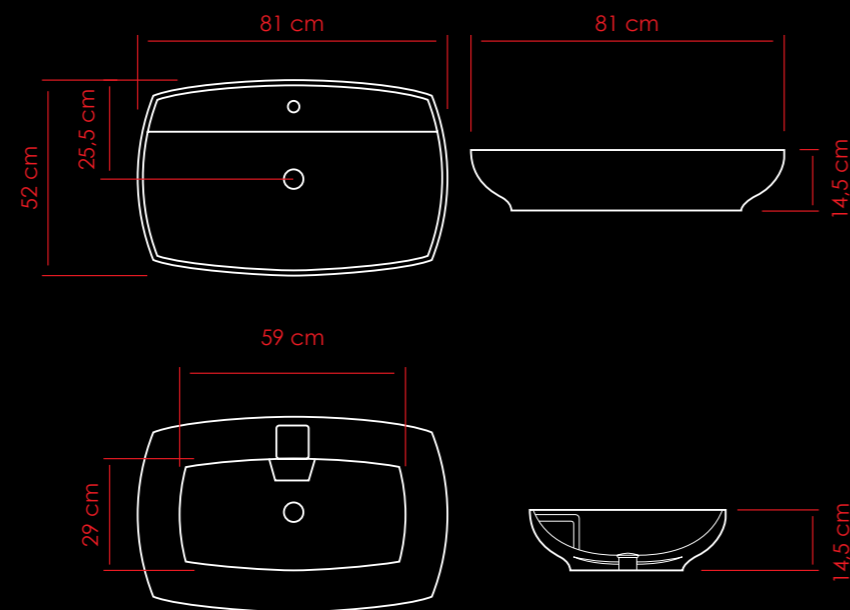

T80
 Lavabo String
 52x81x14,5 cm

ST80
 Staffa di sostegno
 37x34 cm

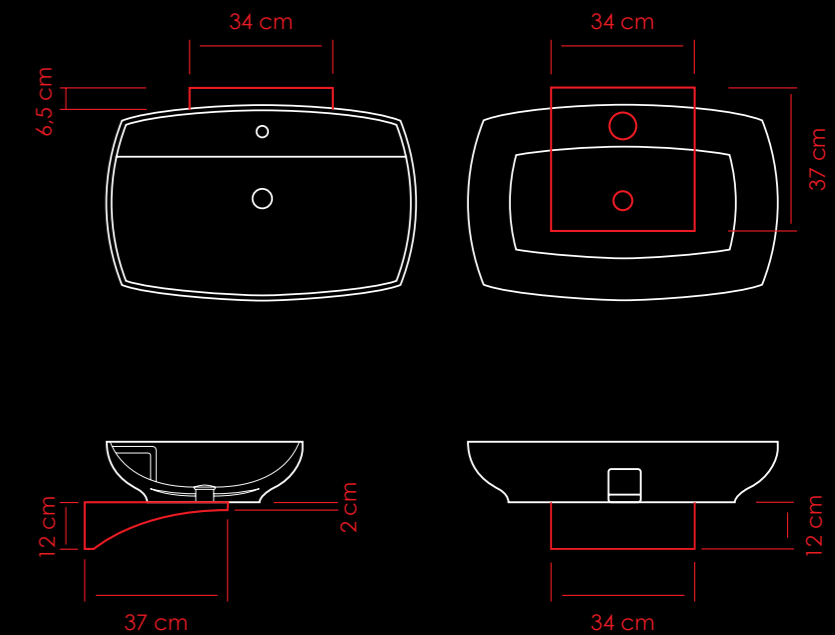



Vaso - WC - УНИТАЗ

TV
Vaso String
38x54 cm

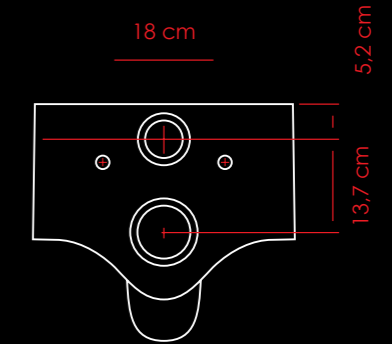
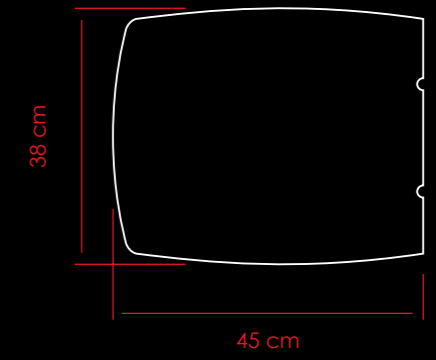
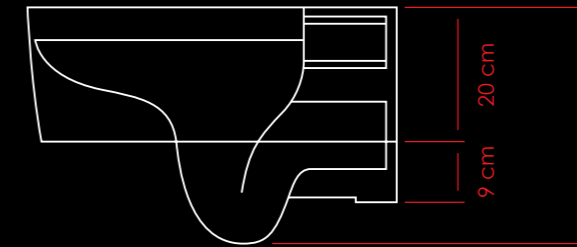
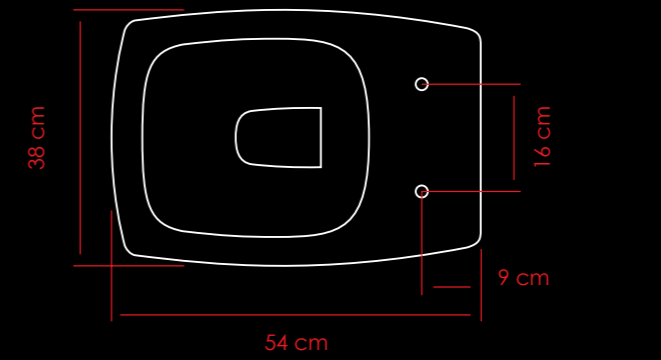

TC
Copri vaso
con chiusura soft

Bidet - Bidet - БИДЕ

TB
Bidet String
38x54 cm

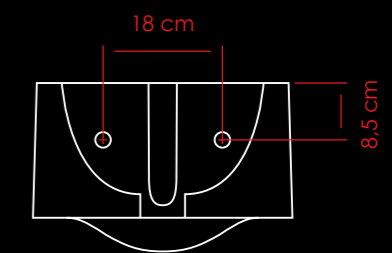
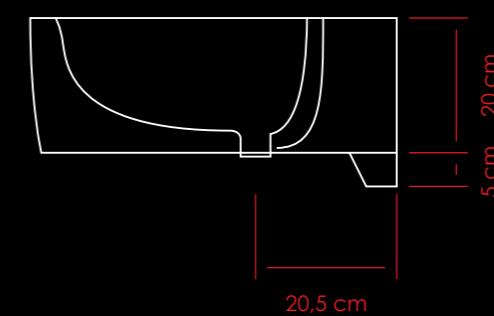
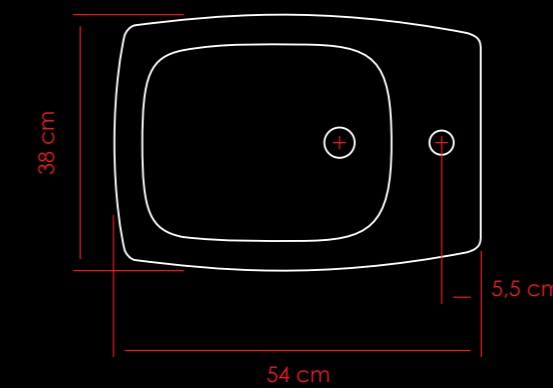

FONDI (Bicottura)

La lavorazione di questi fondi è articolata in più passaggi al fine di creare un prodotto ricercato e curato nel dettaglio. Alla cottura del cottoforte seguono varie lavorazioni: molteplici stratificazioni di smalti e cristalline che rendono il prodotto profondo ed estremamente lucente in superficie. I fondi subiscono una lavorazione a doppio velo, un doppio passaggio di cristalline e smalti che permette di ottenere una profondità di prodotto unica.

In un metro quadrato sono presenti circa 3,2 kg di smalto e cristalline.

Successivamente a queste lavorazioni il prodotto subisce una ulteriore cottura a 1.050 gradi, nel quale lo smalto si fissa al supporto.

I fondi sono disponibili nei formati 20x20 e 20x60, entrambi in spessore 1 cm.

Data la particolare lucentezza e superficie del prodotto si raccomanda di maneggiare con grande cura e di prestare particolare attenzione in fase di posa.

Piccoli fori e leggere imperfezioni in superficie sono il risultato della stesura consistente di smalto e delle successive lavorazioni ricercate.

Possibili effetti craquelè (cavillo) si possono presentare occasionalmente soprattutto dopo la posa, derivanti da sollecitazioni meccaniche di trazione sulla strato consistente di smalto. L'effetto non si presenta se non in rare condizioni. Si consiglia un uso del prodotto da interno, pavimento per ambienti bagno, rivestimento per qualsiasi ambiente.

ISTRUZIONI PER LA POSA E LA STUCCATURA DEL PRODOTTO

Inizialmente si deve procedere ad una corretta preparazione del sottofondo in modo che sia pulito, asciutto ed esente da umidità, senza crepe e non deve presentare dislivelli di planarità.

Si consiglia di utilizzare un adesivo monocomponente per piastrelle in ceramica a base cementizia ad alta adesione, buona deformabilità e scivolamento verticale nullo.

MAPEI KERAFLEX MAXI S1 - MAPEI ELASTORAPID KERAKOLL SPECIAL – KERAKOLL H40 FLEX

Per fughe utilizzare stucco a grana fine, a ridotto assorbimento d'acqua, a presa ed asciugamento rapido. MAPEI ULTRACOLOR PLUS (malta ad alte prestazioni, antiefflore-scenze, idrorepellente, a presa ed asciugamento rapido per la stuccatura di fughe da 2 a 20 mm) KERAKOLL FUGABELLA PORCELANA 0-5 (stucco porcellanato fine professionale monocomponente a tecnologia microgranulare, elevata durezza, ridotto assorbimento d'acqua) KERAKOLL FUGABELLA 2-12 (per le fughe da 2 a 12 mm stucco professionale monocomponente a finitura liscia calibrata, elevata durezza e ridotto assorbimento d'acqua)

Per le caratteristiche e le modalità d'impiego dei materiali indicati si rimanda alle relative schede tecniche.

La Decoratori Bassanesi S.r.l. per nessun motivo accoglierà contestazioni sul materiale posato.

I colori di prodotti riportati nel presente catalogo sono puramente indicativi dei colori reali.

PLAIN TILES (double fired)

These tiles are manufactured by a process involving several stages, designed to produce a stylish and expertly crafted product.

First firing of the ceramic body is followed by a series of steps: multiple layering of glazes and crystalline powders, giving the finished tile a deep and extraordinarily clear lustre. Plain tiles undergo a dual layer process — two applications of crystalline powders and glaze slips combining to produce a finish of unique depth and colour.

One square metre of tiling contains around 3.2 kg of glaze and microcrystal.

Following the sequence of glazing steps, the tiles are fired for a se-cond time at 1,050 degrees to anchor the glaze to the ceramic body.

Plain tiles are made in 20x20 and 20x60 sizes, both 1 cm thick.

Because the particular sheen and texture of the glaze are easily defaced, great care should be taken when handling and during installation.

Any pinholes and minor imperfections in the surface are quite normal, given the thickness of the glaze and the special process adopted.

Crazing may appear in the glaze, especially after the tiles have been bonded to the substrate, due likewise to the depth of the glaze and the mechanical stresses induced during installation. In practice however, this will rarely occur. The product is intended for internal use, typically on bathroom floors, and as a wall covering for any interior.

INSTRUCTIONS FOR INSTALLATION AND GROUTING

The first step is to ensure correct preparation of the substrate, which must be clean, dry, devoid of residual moisture and with no cracks. The surface must be perfectly flat. For best results, select a ready-to-use cement-based tile adhesive with strong bonding properties, good flexibility and zero vertical slippage.

MAPEI KERAFLEX MAXI S1 – MAPEI ELASTORAPID KERAKOLL SPECIAL – KERAKOLL H40 FLEX

Use a fine grade grouting cement with low water absorption, preferably fast-setting and fast-drying. MAPEI ULTRACOLOR PLUS (high performance grouting mortar with efflorescence-inhibiting, water-repellent, fast-setting and fast-drying properties, for gaps of 2 to 20 mm) KERAKOLL FUGABELLA PORCELANA 0-5 (ready-to-use professional vitreous grouting cement featuring microgranule technology; offers superior hardness and low water absorption) KERAKOLL FUGABELLA 2-12 (ready-to-use professional grouting cement featuring smooth finish, superior hardness and low water absorption, for gaps of 2 to 12 mm)

For specifications and recommended use of the materials indica-ted, refer to the relative technical data sheets.

Decoratori Bassanesi S.r.l will under no circumstances accept complaints regarding material post-installation.

Actual product colours may differ from the colours shown in this catalogue, which are purely indicative.

ОДНОТОННАЯ ПЛИТКА (двукратного обжига)

Обработка однотонной плитки выполняется в несколько приемов с целью создания изысканной продукции с тщательно разработанными деталями.

За обжигом бисквита следуют различные этапы обработки: наносятся многочисленные слои цветной и прозрачной глазури, которые придают изделию глубину и чрезвычайно глянцевые поверхности.

Однотонная плитка подвергается обработке с т.н. двойным слоем, то есть двойной этап нанесения прозрачной и цветной глазури, благодаря которому достигается уникальная глубина изделия.

На одном квадратном метре материала имеются прибол. 3,2 кг цветной и прозрачной глазури. После данной обработки изделия еще раз обжигаются при температуре 1050 градусов, и на этом этапе глазурь закрепляется на основе.

Форматы однотонной плитки – 20x20 и 20x60 см, толщина обоих форматов составляет 1 см.

Учитывая специальный глянец и особенности поверхности изделия рекомендуем аккуратно обращаться с ним и быть особенно внимательными во время укладки.

Небольшие отверстия и легкие поверхностные дефекты являются результатом нанесения большого количества глазури и последующей сложной обработки. Возможный эффект кракелюры (трещинок) может возникнуть в любое время, особенно после укладки, в связи с механической тягой на толстый слой глазури. Этот эффект появляется очень редко.

Учитывая специальный глянец и особенности поверхности изделия, рекомендуем аккуратно обращаться с ним и быть особенно внимательными во время укладки.

Данную продукцию рекомендуется использовать в помещениях, для настила полов в ванных комнатах, или же для облицовки стен в любых других помещениях.

ИНСТРУКЦИЯ ПО УКЛАДКЕ ИЗДЕЛИЙ И ЗАДЕЛЫВАНИЮ ШВОВ

Сначала необходимо правильно подготовить подстилающий слой, который должен быть чистым, сухим и без следов влаги, без трещин и перепадов уровня.

Рекомендуем использовать однокомпонентный клей для керамической плитки на цементной основе с высокой склеивающей способностью, хорошей деформируемостью и нулевым вертикальным скольжением.

MAPEI KERAFLEX MAXI S1 - MAPEI ELASTORAPID KERAKOLL SPECIAL – KERAKOLL H40 FLEX

Для швов использовать затирку с мелкой зернистостью, с пониженным поглощением воды, быстросхватывающуюся и быстро сохнущую. MAPEI ULTRACOLOR PLUS (затирка с высокими характеристиками, не образующая налеты, водоотталкивающая, быстросхватывающаяся и быстро сохнущая для заделки швов толщиной от 2 до 20 мм). KERAKOLL FUGABELLA PORCELANA 0-5 (однокомпонентная тонкая фарфоровая затирка для профессионального применения, с микрогранулами, повышенной твердостью и умеренным поглощением воды). KERAKOLL FUGABELLA 2-12 (для швов толщиной от 2 до 12 мм).

Это однокомпонентная затирка для профессионального применения с гладкой калиброванной отделкой, повышенной твердостью и умеренным поглощением воды).

Характеристики и способ применения указанных материалов смотри в соответствующих технических характеристиках.

Компания Decoratori Bassanesi S.r.l. ни в коем случае не принимает претензии по уложенному материалу.

Указанные в настоящем каталоге цвета продукции являются лишь только ориентировочными по сравнению с фактическими.

Cartella colori stucchi

Si suggerisce di utilizzare per ogni colore di fondo lo stucco in coordinato riportato nella cartella.

Grout colour chart

it is advisable to use the matching grout for each colour of plain tile, as indicated in the chart.

ЦВЕТОВАЯ ГАММА ЗАТИРКИ

для каждого цвета однотонной плитки рекомендуем использовать сочетающуюся затирку, указанную в цветовой гамме

Ninfea	Mapei Ultracolor Plus n° 140	Kerakoll Fugabella Porcelana n° 27
Ciclamino	Mapei Ultracolor Plus n° 143	Kerakoll Fugabella Porcelana n° 25
Ortensia	Mapei Ultracolor Plus n° 110	Kerakoll Fugabella Porcelana n° 02
Dalia	Mapei Ultracolor Plus n° 110	Kerakoll Fugabella Porcelana n° 02
Orchidea	Mapei Ultracolor Plus n° 112	Kerakoll Fugabella Porcelana n° 03
Edera	Mapei Ultracolor Plus n° 112	Kerakoll Fugabella Porcelana n° 03
Narciso	Mapei Ultracolor Plus n° 100	Kerakoll Fugabella Porcelana n° 01
Gardenia	Mapei Ultracolor Plus n° 100	Kerakoll Fugabella Porcelana n° 01
Gerbera	Mapei Ultracolor Plus n° 130	Kerakoll Fugabella Porcelana n° 07
Calicanto	Mapei Ultracolor Plus n° 144	Kerakoll Fugabella Porcelana n° 12
Eleboro	Mapei Ultracolor Plus n° 120	Kerakoll Fugabella Porcelana n° 05



Decoratori Bassanesi srl

Sede legale: Largo Perlasca, 19 - 36061 Bassano del Grappa (VI)
Uffici e deposito: Via Vallina Orticella, 48 - 31030 Borso del Grappa (TV)
Tel. 0423 910076 - Fax 0423 561188
info@decoratoristyle.it - www.decoratoristyle.it